

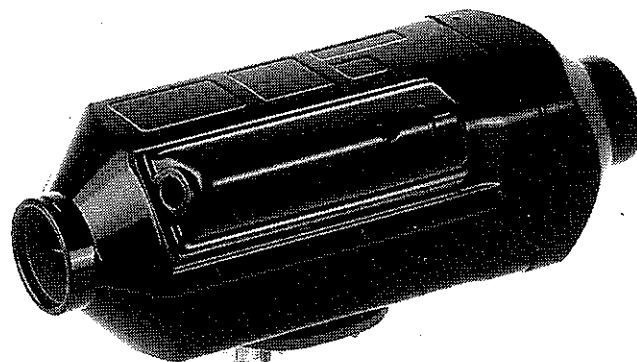

Espar

**D1LC** *compact*

**INSTALLATION  
TROUBLESHOOTING  
& PARTS MANUAL**



**MARCH 1996**

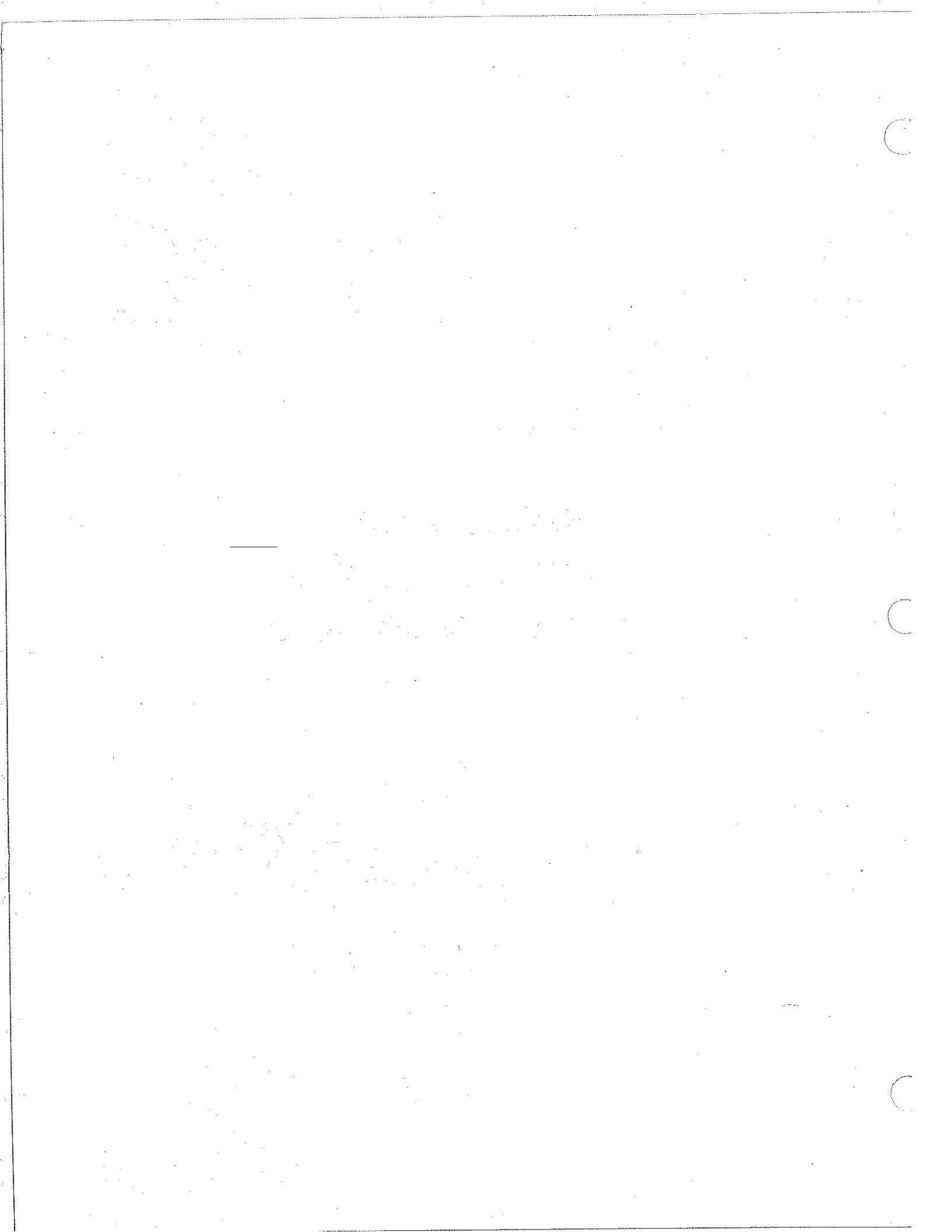

# TABLE OF CONTENTS

## I. INTRODUCTION

Page 1-6

- 1) General Specifications
- 2) Heater Warnings
- 3) Introduction
- 4) Principal Dimensions
- 5) Mounting Pattern
- 6) Heater Components

## II. INSTALLATION PROCEDURES

Page 7-14

- 1) Heater Location
- 2) Heater Mounting
- 3) Heater Air Ducting
- 4) Fuel System
- 5) Electrical Connections
- 6) Exhaust & Combustion Air Intake Connections
- 7) Operating Switches

## III. HEATER OPERATION

Page 15-17

- 1) Switch On
- 2) Start Up
- 3) Temperature Setting
- 4) Temperature Control
- 5) Switch Off
- 6) Controls and Safety Equipment
- 7) Operation Flow Chart

## IV. MAINTENANCE, TROUBLESHOOTING & REPAIRS

Page 18-31

- 1) Recommended Periodic Maintenance
- 2) Wiring Diagram
- 3) Basic Troubleshooting
- 4) Self Diagnostics
- 5) Fuel Quantity Test
- 6) Components Specification Chart
- 7) Repair Steps

## V. HEATER PARTS SECTION

Page 32-39

- 1) D1LC Compact - Service Parts Diagram
- 2) D1LC Compact - Parts List

### SPECIAL NOTES

**Note:** Highlight areas requiring special attention or clarification.

**Caution:** Indicates that personal injury or damage to equipment may occur unless specific guidelines are followed.



**Warning:** Indicates that serious or fatal injury may result if specific guidelines are not followed.

## 1. GENERAL SPECIFICATIONS

Model 25 1895 05 12V  
25 1896 05 24V

**Heat Output ( $\pm 10\%$ )**  
7,500 BTU/hr Boost  
6,150 BTU/hr High  
4,100 BTU/hr Medium  
2,900 BTU/hr Low

**Current at 12v ( $\pm 10\%$ )**  
20.8 amps/hr - Start  
2.5 amps/hr - Boost  
1.8 amps/hr - High  
0.8 amps/hr - Medium  
0.8 amps/hr - Low

**Current at 24v ( $\pm 10\%$ )**  
11.25 amps/hr - Start  
1.25 amps/hr - Boost  
0.9 amps/hr - High  
0.4 amps/hr - Medium  
0.4 amps/hr - Low

<b>Fuel Consumption (<math>\pm 10\%</math>)</b>	U.S. Gal/hr	Imp Gal/hr	Litre/hr
Boost	.07	.06	.27
High	.06	.04	.21
Medium	.04	.03	.14
Low	.03	.02	.10

**Air Flow ( $\pm 10\%$ )**  
50 cfm Boost  
43 cfm High  
30 cfm Medium  
30 cfm Low

**Operating Voltage Range**  
10.5 to 15.9 vdc at 12 vdc  
21.0 to 31.8 vdc at 24 vdc

**Overheat Temperature  
Shutdown ( $\pm 10\%$ )**  
240°F (116°C)

**Ambient Operating  
Temperature**  
-40°F to 122°F (-40°C to 50°C)

**Note:** The heater control unit is equipped with a low voltage cutout to prevent vehicle battery drain and a high voltage cutout to protect heater electrical parts.

## 2. HEATER WARNINGS

**Warning To Installer:** Correct installation of this heater is necessary to ensure safe and proper operation. Read and understand this manual before attempting to install a heater.



### Warning - Explosion Hazard

1. Heater must be turned off while re-fueling.
2. Do not install heater in enclosed areas where combustible fumes may be present.
3. Do not install heaters in engine compartments of gasoline powered boats.



### Warning - Fire Hazard

1. Install heater so it will maintain a minimum distance of 2" from any flammable or heat sensitive material.
2. Install the exhaust system so it will maintain a minimum distance of 2" from any flammable or heat sensitive material.
3. Ensure that the fuel system is intact and there are no leaks.

**Failure to follow these instructions could cause fire resulting in serious or fatal injury.**



### Warning - Asphyxiation Hazard

1. Route the heater exhaust so that exhaust fumes cannot enter any passenger compartments.
2. Ensure an air tight seal will be maintained between the heater and mounting surface and at any exhaust connection points.
3. Ensure that heating air supply is taken from an area where poisonous gases will not be present.
4. If running exhaust components through an enclosed compartment, ensure that it is vented to the outside.

**Failure to follow these instructions could cause oxygen depletion resulting in serious or fatal injury.**

Direct questions to Espar Heater Systems

**USA 1-800-387-4800**

**CDA 1-800-668-5676**

## ESPAR D1LC COMPACT AIR HEATER

### 3. INTRODUCTION

#### Espar D1LC Compact Air Heater - Heater Introduction

The ESPAR D1LC Compact is a diesel-fired 7,500 BTU/HR air heater, quality engineered to provide a dependable means of space heating. This heater is uniquely designed for inside mounting and ease of installation.

The heater provides hot air to the interior of vehicles for passenger comfort. Since the heater runs on diesel fuel and 12 or 24 volt power, it is able to perform this completely independent of the vehicle engine.

The heater is operated by a rheostat switch or room thermostat. The heater will cycle through four temperature settings (boost-high-medium-low) in order to maintain the desired temperature. If, in special cases, even less heating capacity is required than the heater supplies in the "Low" setting, it switches to the "Off" setting. Temperature and overheat limit switches, and a specially designed heat exchanger are among the safety features which make this heater a safe and dependable unit.

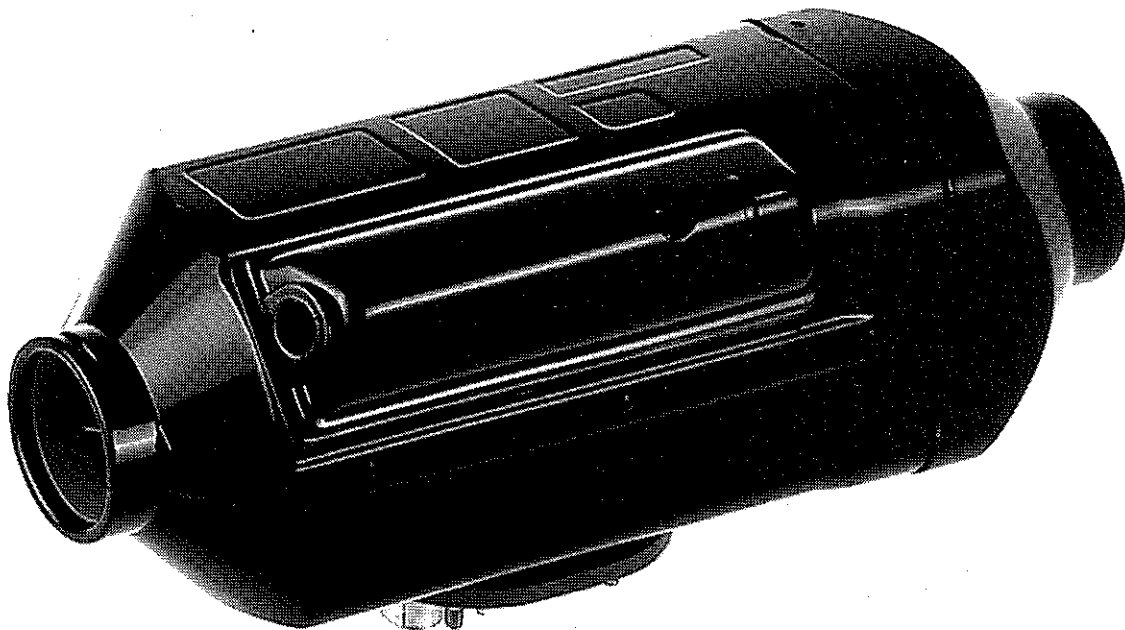

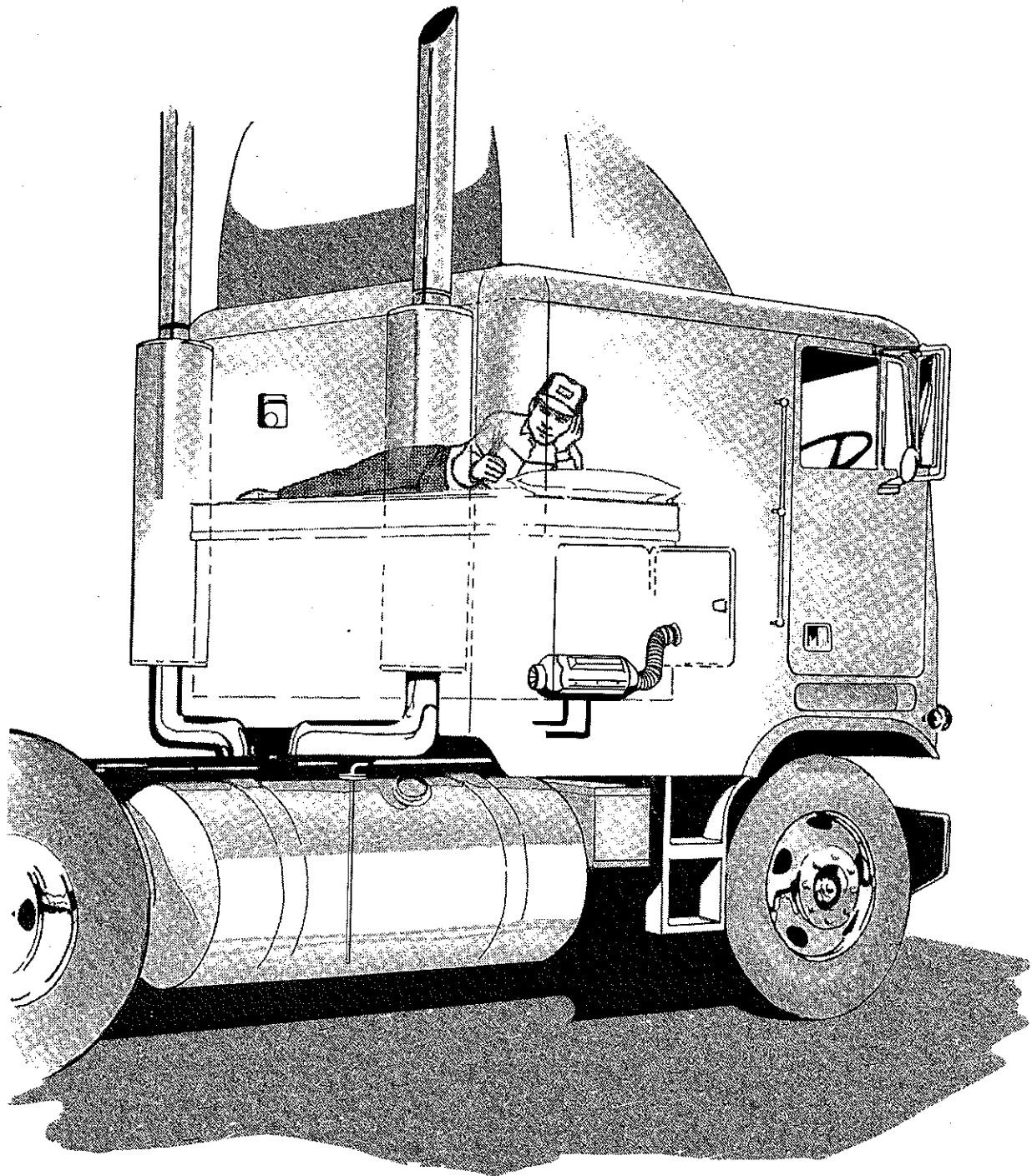

#### 4. PRINCIPAL DIMENSIONS

**Figure IA**

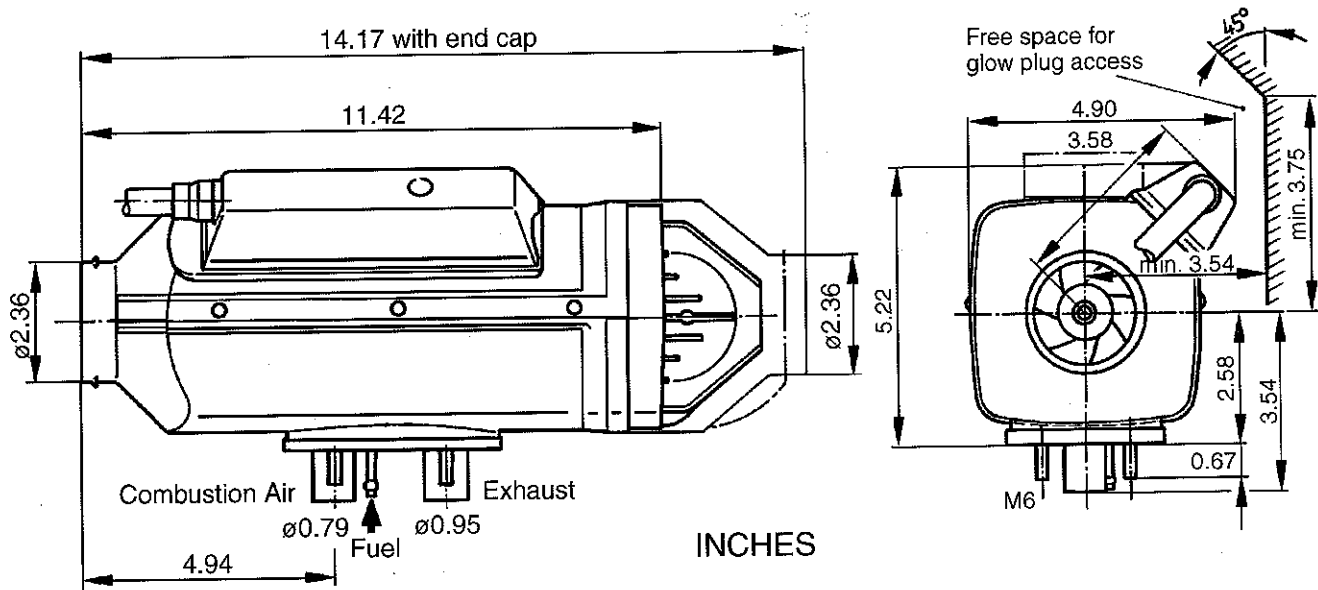

#### 5. MOUNTING PATTERN

If fastening to the vehicle wall/floor, make penetrations in accordance with the hole pattern (**Figure IB**). A pre-punched mounting kit is also available as shown.

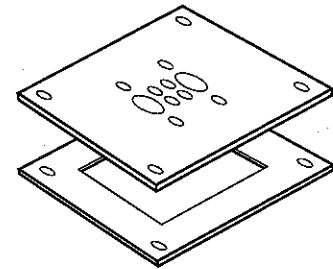

**Figure IB**

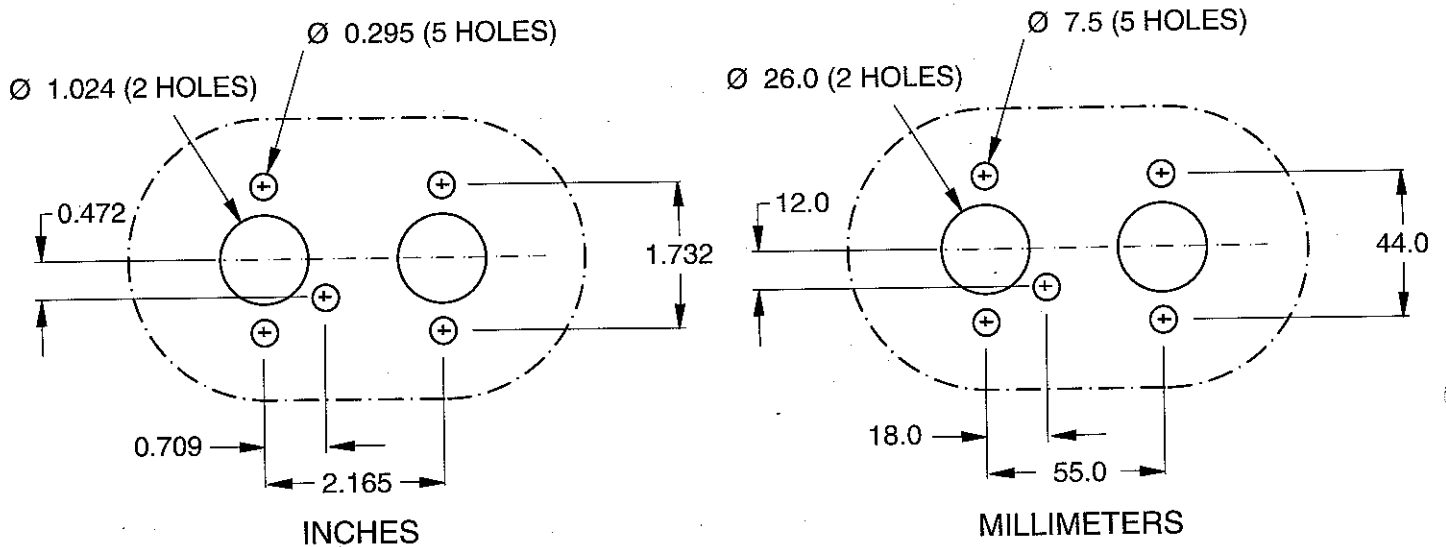



## 6. HEATER COMPONENTS

Figure IC

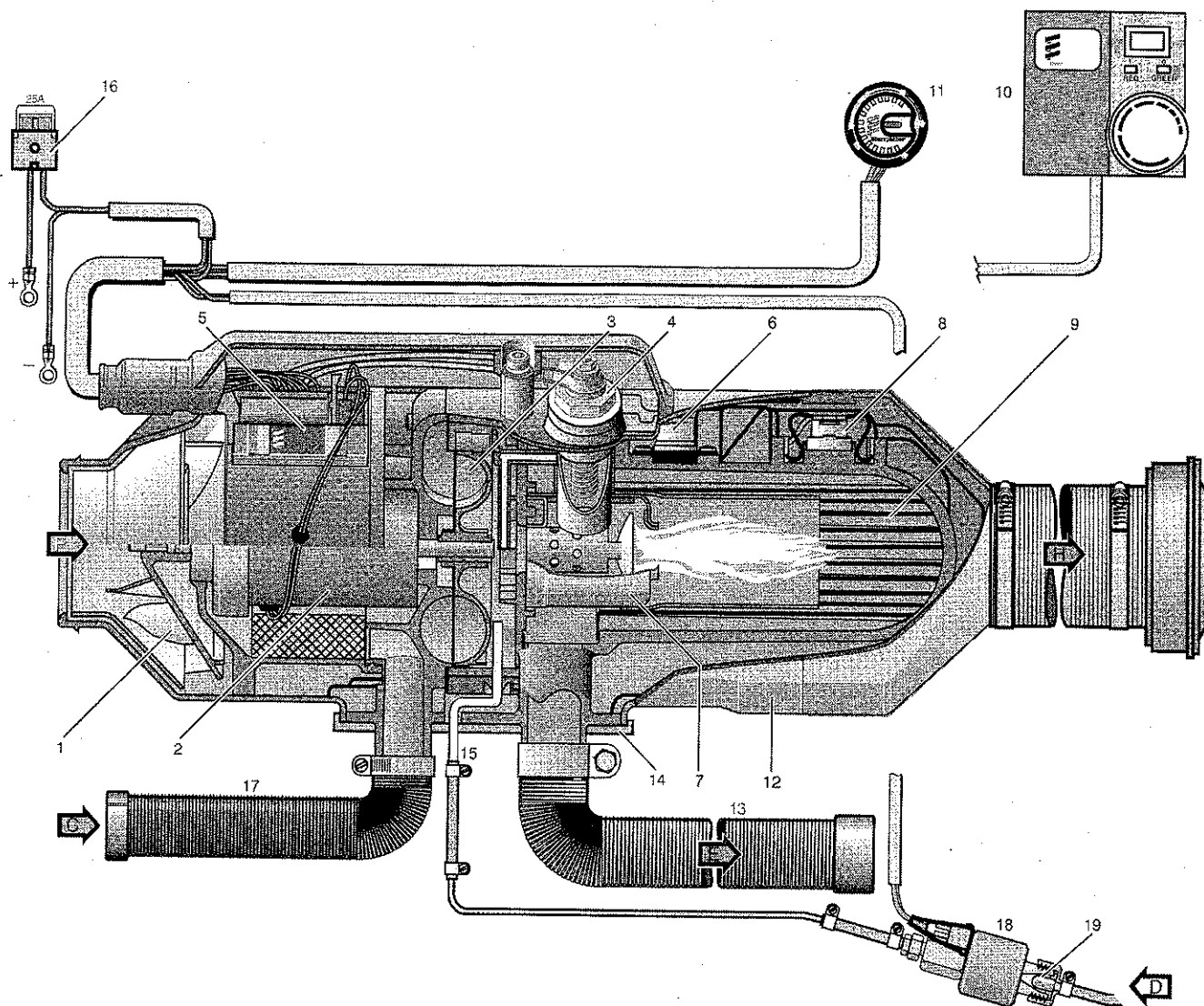

### PARTS LIST

- |                                |                               |                           |
|--------------------------------|-------------------------------|---------------------------|
| 1 Hot Air Blower Wheel         | 11 Operating Unit (Rheostat)  | <b>F = Fresh Air</b>      |
| 2 Blower Motor                 | 12 Outer Casing               | <b>C = Combustion Air</b> |
| 3 Combustion Air Blower Wheel  | 13 Exhaust Line               | <b>D = Fuel</b>           |
| 4 Glow Plug                    | 14 Flange Seal                | <b>H = Hot Air</b>        |
| 5 Control Unit                 | 15 Fuel Line                  | <b>E = Exhaust</b>        |
| 6 Safety Thermal Sensor        | 16 Main Fuse, 25 A            |                           |
| 7 Combustion Chamber           | 17 Combustion Air Intake Line |                           |
| 8 Flame Monitor                | 18 Fuel Metering Pump         |                           |
| 9 Heat Exchanger               | 19 Fuel Strainer              |                           |
| 10 Operating Unit (Thermostat) |                               |                           |

## II. INSTALLATION PROCEDURES

### 1. HEATER LOCATION

Depending on the type of vehicle, the best location for mounting the heater will vary. Typically, heaters are mounted inside tool or luggage compartments. However, the heater may be mounted anywhere inside the vehicle provided you adhere to the following conditions:

- Combustion air intake, exhaust and fuel inlet must be located outside of vehicle.
- Heater must be mounted on flat horizontal surface providing an air tight seal between heater and vehicle.
- Do not mount the heater outside the vehicle, unless care is taken to protect the heater from the weather.

When selecting the location, consider the following:

- Combustion air and exhaust connections.
- Ducting.
- Fuel line connections.
- Electrical connections.

### 2. HEATER MOUNTING

A mounting plate and hardware are provided with the heater kit.

- Choose heater location.
- Using template provided, drill and cut center hole. Cut one (1) four and one half inch (4 1/2") diameter hole or one rectangular hole four (4") by five (5") inches.
- Mount heater on mounting plate with nuts and spring washers provided.
- For ease of installation make the exhaust, combustion air intake and fuel connections at base of heater before mounting the heater into the vehicle.
- Position heater in vehicle and secure with "Tek" screws provided.

**Note:** Tighten screws sufficiently to ensure positive seal between mounting plate and mounting surface. **Do not** over tighten.

### HEATER MOUNTING PLATE INSTALLATION

**Figure IIA**

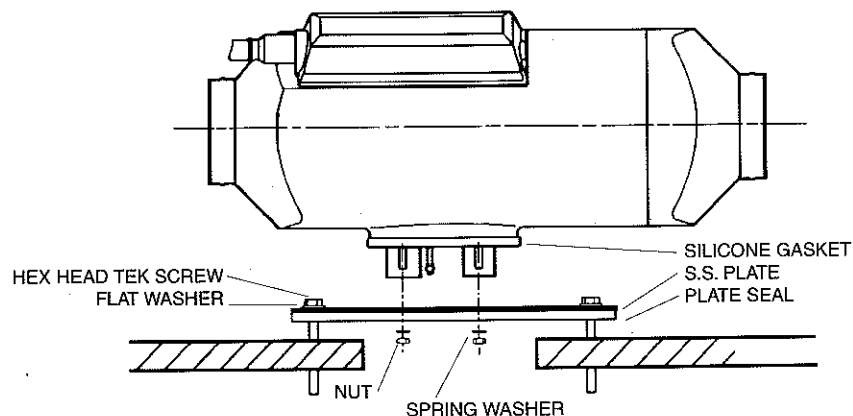

### 3. HEATER AIR DUCTING

#### A) Installation

A 60mm flexible duct 40 inches long, hot air outlet and clamps are provided with the heater kit.

In routing and installing the ducting the following criteria must be observed:

- Run ducting with smooth bends. Avoid crushing duct.
- Position hot air outlet so that it cannot be obstructed.
- Use protective air intake grille on air inlet side of heater to prevent objects from being sucked in.
- Ensure provisions are made for proper air return ventilation.
- Use return air ducting for best heating efficiency (refer to **Figure II B**).

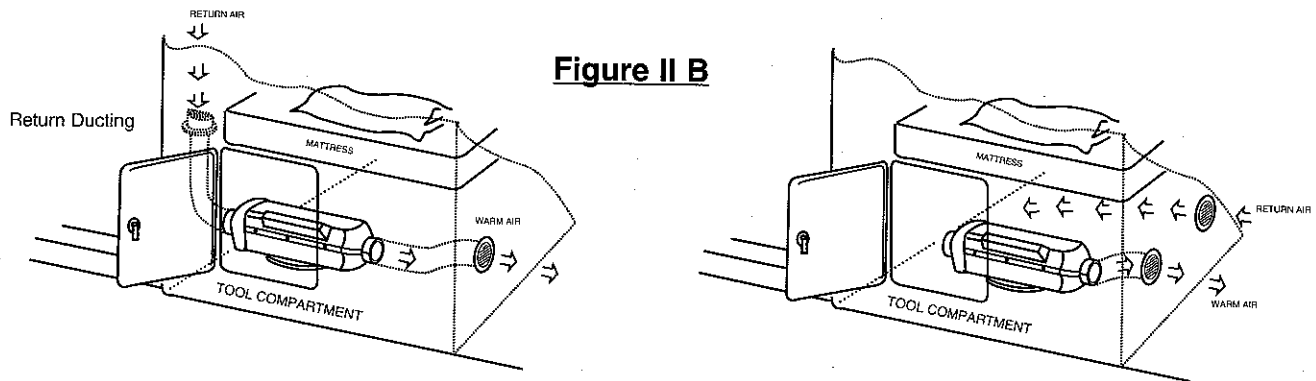

**Figure II B**

#### Ducting Components Figure II C

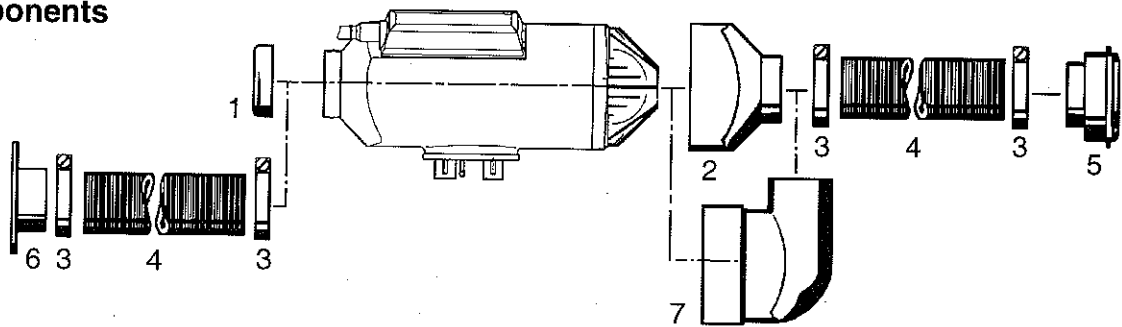

1. Protective Grill  
2. Air Outlet Hood

3. Hose Clamp 2-2 3/4"  
4. Flex Duct 2 3/8"

5. Air Outlet - Rotatable  
6. Connection Piece  
7. 90° Bend Ducting 2 3/8"



**Warning:** Do not use existing vehicle ducting or outlets. Ducts and outlets must be capable of withstanding a minimum of 300°F operating temperatures. To avoid exhaust leakage, the heater must always be operated with an end cap installed.

#### **Caution:**

Do not overtighten duct clamps.  
Do not position outlet so that it will blow hot air directly at operator or at room thermostat.

## 4. FUEL SYSTEM

The fuel metering pump is the heart of the system and must be installed properly to ensure a successful heater operation.

### A) Figure II D: Fuel System Overview

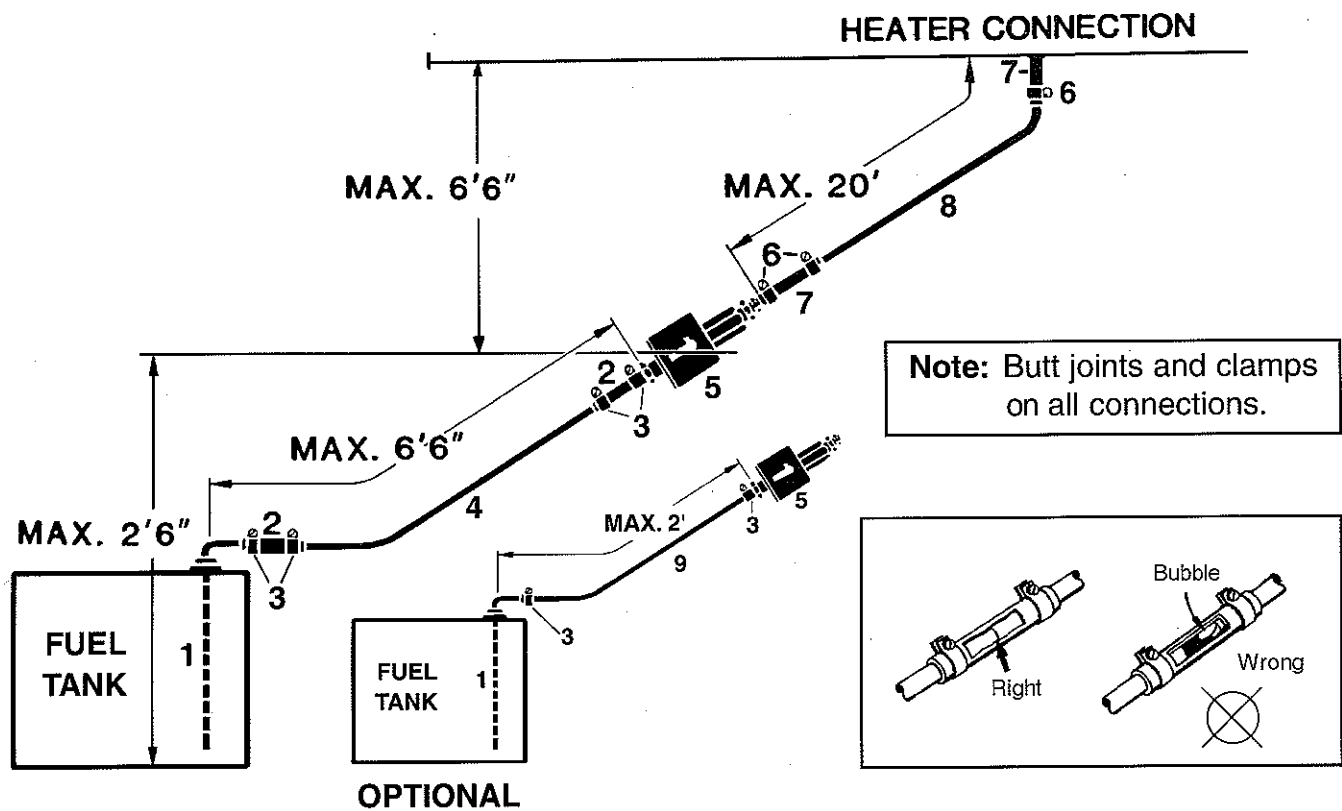

1. Fuel Pick-Up Pipe
2. 5.0 Rubber Connector
3. 11mm Clamp
4. 2.0mm Black Plastic Fuel Line

5. Fuel Metering Pump
6. 9mm Clamp
7. 3.5mm Rubber Connector
8. 1.5mm White Plastic Fuel Line
9. 5mm Rubber Fuel Line

## B) Fuel Pick-Up Pipe Installation (Standard Pick-Up)

- Choose a protected mounting location close to the fuel pump and heater. A spare fuel sender gauge plate provides an ideal mounting location.
- Drill the mounting holes as shown in **Figure II E**.
- Cut the fuel pick-up pipe to length.
- Mount the fuel pick-up pipe as shown in **Figure II F**.
- Lower the fuel pick-up pipe (with reinforcing washer) into the tank using the slot created by the two 1/4" holes.
- Lift the assembly into position through the 1" hole.
- Assemble the rubber washer, metal cup washer and nut.

**Note:** Drill the two 1/4" holes first.

**Figure II E**

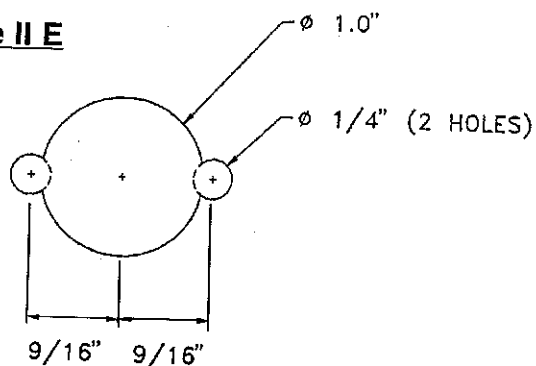

**Figure II F**

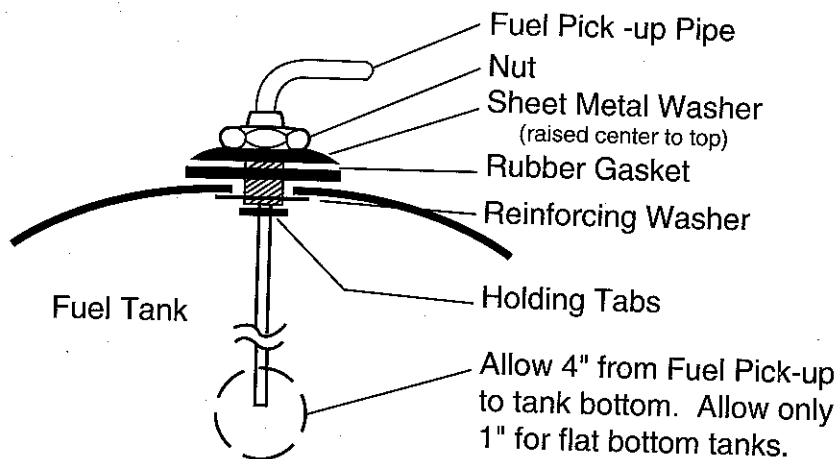

**Figure II G**

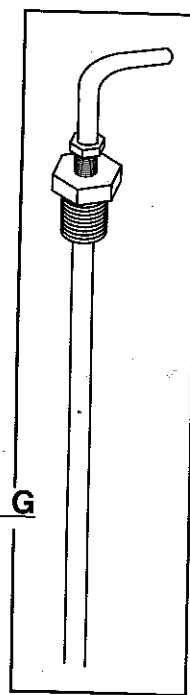

### ( Custom Pick-Up Pipe with NPT fitting )

- Remove an existing plug from the top of the fuel tank.
- Cut the fuel pick-up pipe to length.
- Secure the fuel pick-up pipe into position using the combined NPT compression fitting as shown in **Figure II G**.

**Note:** NPT fittings are available in various sizes (Refer to parts section).

### C) Fuel Metering Pump

- Choose a protected mounting location close to the fuel pick-up pipe and heater.
- Using the bracket and rubber mount provided, install fuel pump as shown in **Figure II H**

**Note:** Proper mounting angle of the fuel pump is necessary to allow any air or vapor in the fuel lines to pass through the pump rather than cause a blockage.

**Figure II H: Fuel Pump Installation**

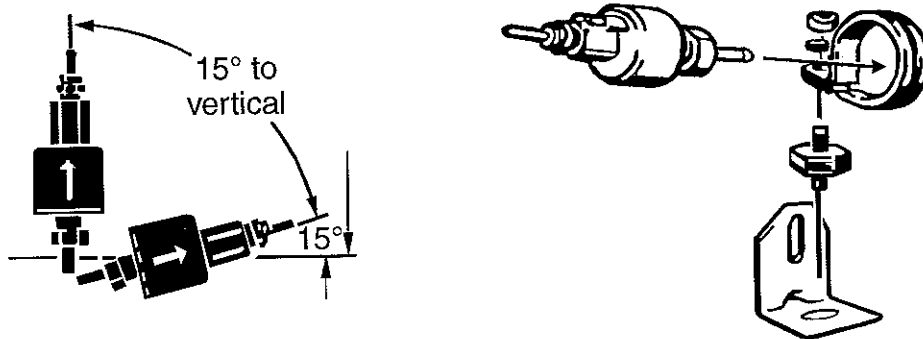

### D) Fuel Line

- Route fuel lines from the fuel pick-up pipe to the fuel metering pump then to the heater.
- Use fuel lines provided.
- Other sizes or types of fuel lines may inhibit proper fuel flow.
- Make proper butt joints using clamps and connector pieces as shown in **Figure II D**.
- Use a sharp utility knife to cut plastic fuel lines to avoid burrs.

## 5. ELECTRICAL CONNECTIONS

**Caution:** Install power fuse only after all electrical connections are complete.

- A) Main Harness**
- 11 core harness (red/white, green/red, blue/white, red, white, grey/red, grey, brown, brown, brown/white and yellow).
  - Connect to heater control unit (mounted in heater) using the 14 pin connector.
  - Connect glow plug connector.
  - Place protective hood over glow plug and control unit and secure.
  - Connect to other harnesses as described for each harness.
- B) Power Harness**
- 2 core harness (red and brown).
  - Connect red wire to fuse holder near battery.
  - Connect red fuse link wire to other side of fuse holder.
  - Connect other end of fuse link wire directly to battery positive post using ring terminal provided.
  - Connect brown wire directly to battery negative post using ring terminal provided.
  - Connect power harness to main harness using 2 pin connector.
- C) Switch Harness**
- 6 core harness (red, brown/white, yellow, grey, blue/white and grey/red).
  - Connect to rheostat switch or thermostat (refer to switch connection section).
  - Connect switch harness to main harness using 6 pin connector.
- D) Fuel Metering Pump Harness**
- 2 core harness (green/red and brown).
  - Connect to fuel metering pump using single terminals and rubber protective boots (no polarity required).
  - Connect fuel metering pump harness to main harness using two single connectors.

### Electrical Connections

Figure II I

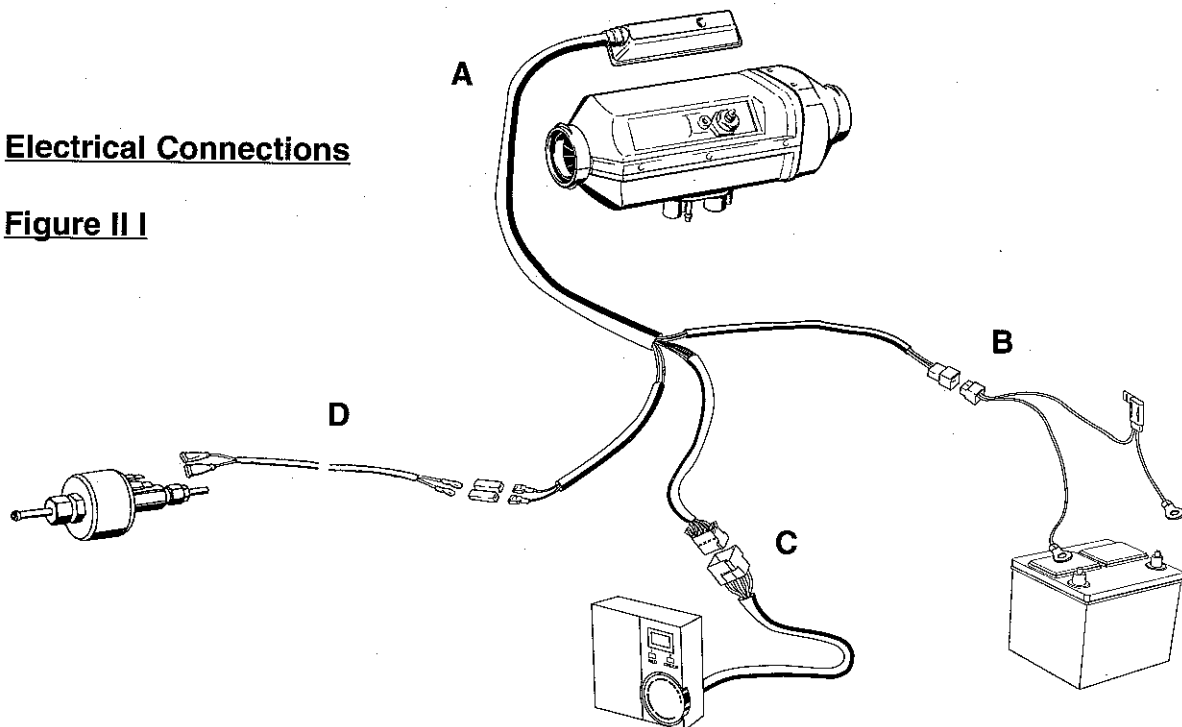

**Note:** All exposed electrical connections should be coated with protective grease, (petroleum gel, Vaseline, etc.).

## 6. EXHAUST & COMBUSTION AIR INTAKE CONNECTIONS

A 24mm flexible stainless steel exhaust pipe (39" long) and a 20mm flexible plastic tube (39" long) for combustion air intake are included with the heater kit. Exhaust clamps and holders are also provided.

**Caution:**

- Run exhaust and combustion air intakes so they cannot be plugged by dirt, water or snow. Ensure the outlets do not face into the vehicle slip stream.
- Keep exhaust and combustion air intake a minimum of 12" apart.
- Drill 1/8" holes where necessary to allow water drainage.
- Balance the exhaust pipe length with the combustion air intake length.
- Combustion air intake and exhaust lengths can be shortened to a minimum of 8".

- Attach the exhaust pipe to the exhaust outlet of the heat exchanger (**Figure II J**).
- Run to an open area to the rear or side of the vehicle so that fumes cannot build up and enter the cab or the combustion air inlet to the heater.
- Install protective cap.
- Attach the combustion air intake tube to the combustion air inlet of the heater (**Figure II J**).
- Once secure to the heater inlet, the intake pipe must run to the underside of the vehicle where it will pick up clean, fresh, moisture free air.

**Figure II J**

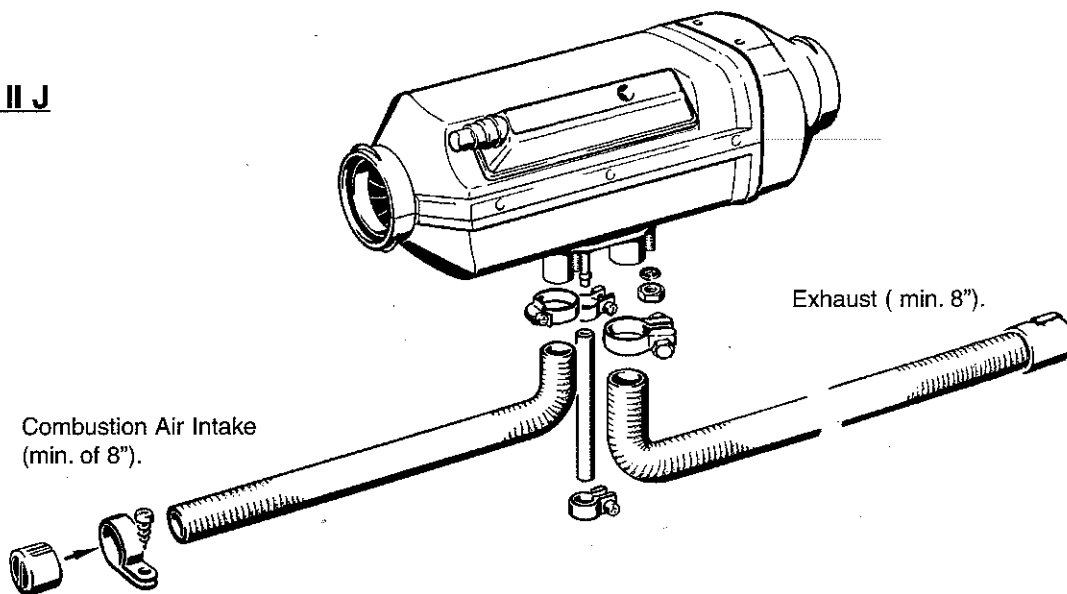

**WARNING:** The exhaust is hot, keep a minimum of 2" clearance from any heat sensitive material



**WARNING:** Route exhaust so that the exhaust fumes cannot enter the passenger compartment.



## 7. OPERATING SWITCHES

The heater can be controlled using a **Thermostat** or **Rheostat** type switch.

### A. Thermostat

- Mount the thermostat in a location where it is easily accessible and it's temperature sensor is representative of the area being heated.
- Mount using the mounting slots in it's base.
- Connect the six core switch harness to the thermostat as shown in **Figure II K**.

**Figure II K**

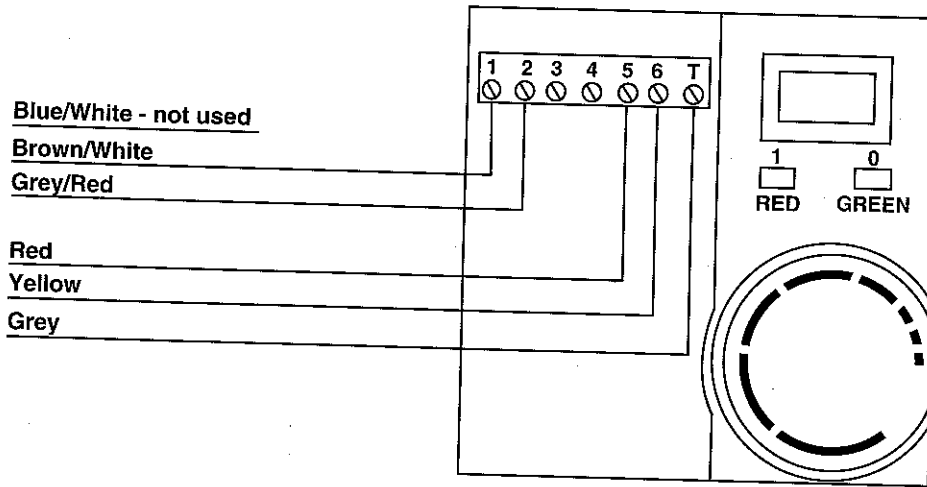

### B. Rheostat Switch

**Note:** When using this option, return ducting must be used as shown in **Figure II B**. This will allow the heater's internal sensor to properly monitor cab temperature.

- Mount the rheostat switch in a location where it is easily accessible.
- Connect the six core switch harness as shown in **Figure II L**.

**Figure II L**

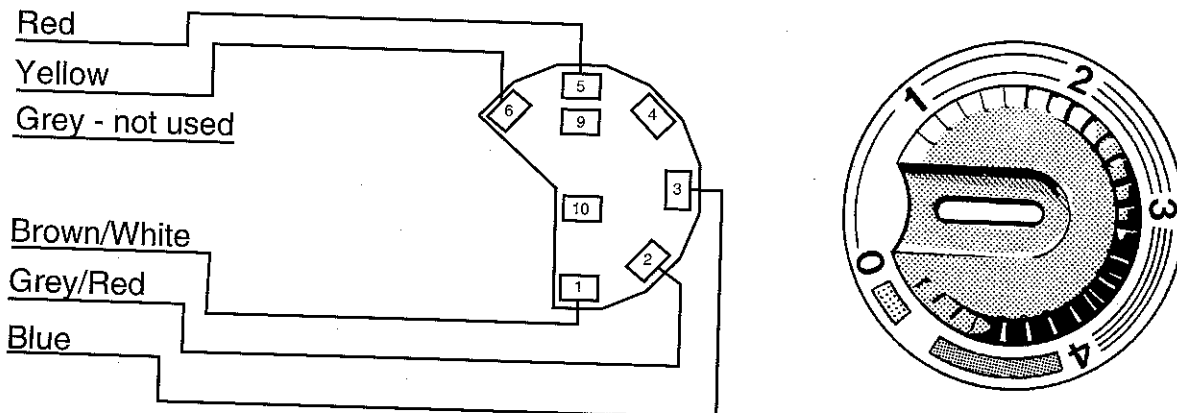

### III. HEATER OPERATION

- Warning:** To prevent fire, the heater must be switched off while filling fuel tanks. To prevent asphyxiation, the heater must not be operated in enclosed areas.

#### 1. SWITCH ON

- Switch the heater on using the room thermostat's, On/Off switch (**1=On, 0=Off**) or the rheostat switch.

#### 2. START UP

On start up the indicator light illuminates and the following sequences take place:

- Control unit does a systems check (glow plug, flame sensor, temperature sensor, safety thermal sensor).
- Blower starts slowly and begins to accelerate.
- Glow plug is energized and starts preheating the combustion chamber.
- After a short delay (approximately 15 seconds) the fuel pump delivers fuel.
- Ignition will take place as the fuel/air mixture contact the glow plug.
- Blower speed and fuel delivery are slowly increased.
- Once flame is established the glow plug will switch off.
- Heater will begin heating.

#### 3. TEMPERATURE SETTING

Using the adjusting dial, set the desired temperature range.

- Lowest Setting - approx. 50°F
- Highest Setting - approx. 85°F
- Mid- Setting- approx. 65°F

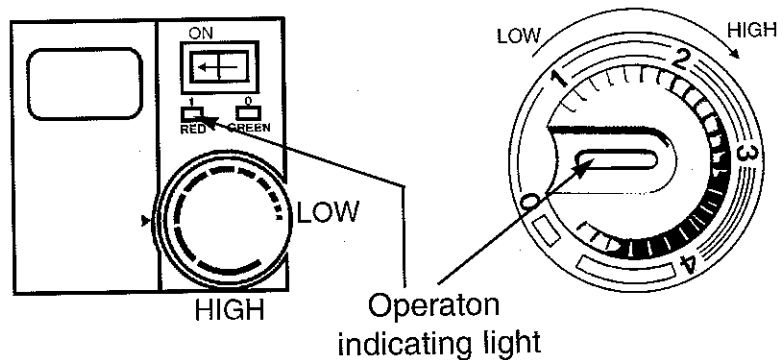

#### 4. TEMPERATURE CONTROL

- The temperature is monitored constantly at the heater intake or thermostat.
- This temperature is compared to the set temperature on the adjusting dial.
- The heater cycles through Boost, High, Medium and Low heat modes to maintain the desired temperature.
- If the desired temperature is exceeded while the heater is operating in low heat mode the heater will switch off. This is a comfort feature.
- The heater will re-start in medium heat mode once heat is again required.

## 5. SWITCH OFF





Once switched off either manually or automatically, the heater begins a controlled cool down cycle.

- The fuel pump stops delivering fuel.
- The glow plug is re-energized for a 15 second after glow.
- The blower continues to run for 3 minutes and automatically switches off.

## 6. CONTROLS AND SAFETY EQUIPMENT

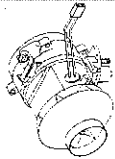
- If the heater fails to ignite within two 90 second start attempts, a "no start" shut down occurs.
- If a flame out occurs after the heater has started, the heater will attempt to restart.
- If repeated flame outs occur within 10 minutes the heater will not restart.
- Overheat shut down will occur if there is a restriction of the heating air flow (i.e. blocked inlet or outlet). The overheat switch will automatically reset once the heater has cooled down. Once the air flow restriction is removed, the heater can be re-started by switching the heater off then back on.
- If the voltage drops below 10.5 volts or rises above 15.9 volts the heater will shut down (21volts and 30 volts for 24 volt systems).
- If the glow plug circuit or fuel metering pump circuit are interrupted the heater will not start.
- The blower motor is checked on start up and every 4 minutes. Shut down will occur if the blower does not start or maintain proper speed.

7. OPERATING FLOW CHART

	STARTING PHASE			RUNNING PHASE		SHUT DOWN PHASE				
 Blower	Off	On	On	On	On	On	On	Off		
 Glow Plug	Off	On	On	OFF	OFF	On	Off	Off		
 Fuel Pump	Off	On	Off	On	On	On	Off	Off		
<b>Operating Mode</b>	System Check	Pre-heat	Ignition Attempt	Pre-heat 2nd. attempt	Ignition Attempt 2nd. attempt	Boost	Controlled Heating	After Glow	Cool Down	Off or Stand by
 Time	1-3 sec.	15 sec.	Up to 90 sec.	15 sec.	Up to 90 sec. If Required			15 sec.	3 min.	
					Time dependent on heat exchanger temperature		Continual Operation until switched off by operator or temperature control			

Note: During controlled heating cycle, if desired heat level is exceeded the heater will cycle off.  
Heater will automatically restart in medium mode once heat is again required



## IV. MAINTENANCE, TROUBLESHOOTING AND REPAIRS

### 1. RECOMMENDED PERIODIC MAINTENANCE

- Remove the **glow plug** and inspect for carbon build up. Clean or replace.
- Remove the **glow plug screen** and inspect for carbon build up. Clean or replace. If cleaning is required, use brass brush (Espar part number CA0 05 003).
- Make sure **vent hole** is open. Espar recommends the use of nondetergent 100% volatile carburetor cleaner and an air gun will also help. Remove loose carbon from the glow plug chamber.
- Inspect the **ducting**, the air intake screen and air outlet for restriction or blockage.
- Inspect combustion air **intake and exhaust** for blockage.
- Run your heater and check for proper operation during **regular Preventative Maintenance** throughout the year.
- **Maintain your batteries** and all electrical connections in good condition. With insufficient power the heater will not start. Low and high voltage cutouts will shut the heater down automatically.
- **Use fuel suitable for the climate** (see engine manufacturers recommendations). Blending used engine oil with diesel fuel is not permitted.

**D11LCcompact**  
**2. WIRING DIAGRAM**

Models: 25 1895 05 (12v)  
 25 1896 05 (24v)

- 1.1 Blower Motor
- 1.2 Glow Plug
- 1.5 Saftey Thermal Sensor
- 1.12 Flame Monitor
- 2.1 Control Unit
- 2.2 Fuel Metering Pump
- 3.1.11 Rheostat
- 3.5 Thermostat
- 5.1 Battery

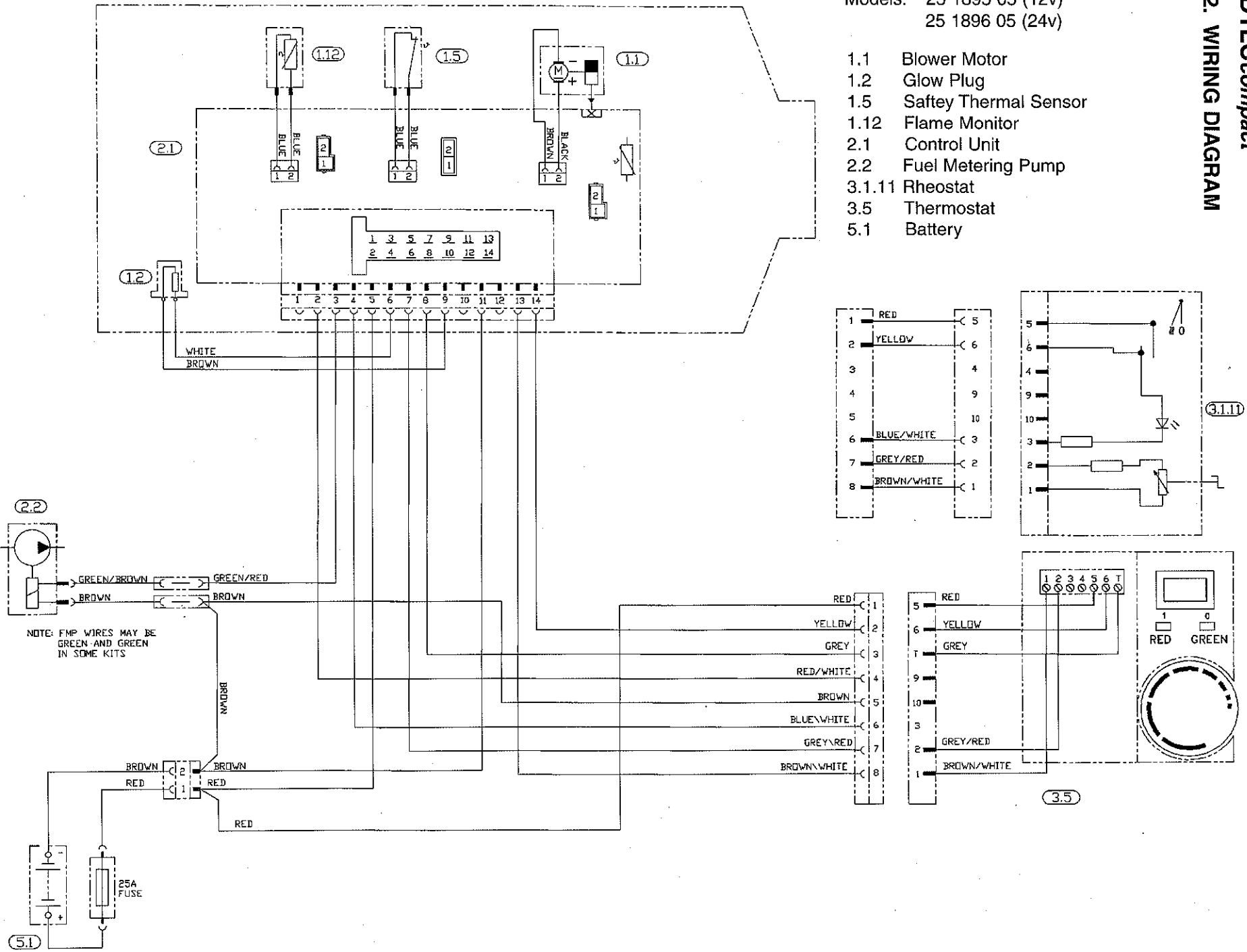

NOTE: FMP WIRES MAY BE GREEN AND GREEN IN SOME KITS

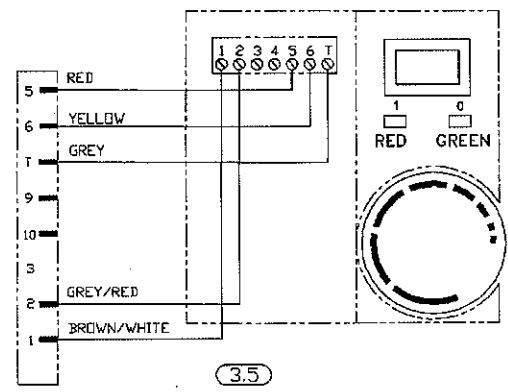
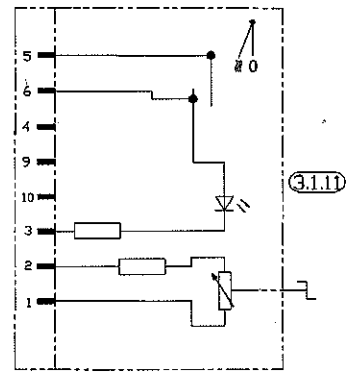
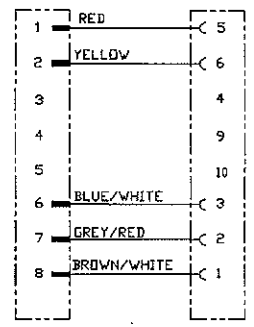

### 3. BASIC TROUBLESHOOTING

#### BASIC CHECK LIST:

What happens when the heater is switched on and ....

#### A) Heater does not ignite

##### 1) Blower motor does not run

- Check:**
- Fuse in power harness.
  - Power to control unit.
  - Power to switch.
  - Electrical connections.

##### 2) Blower motor runs approximately 20 seconds and then shuts off

- Check:**
- Ensure voltage at control unit remains above 9.5 volts during start up with glow plug circuit on.

##### 3) Blower motor runs/fuel metering pump starts and then shuts down after two 90 second start up cycles

- Check:**
- Fuel lines and fuel filter.
  - Fuel quantity.
  - Combustion air or exhaust tube blockage.

##### 4) Blower motor runs/no fuel metering pump

- Check:**
- For electrical pulses at fuel metering pump.
  - If pump is frozen.
  - Blocked fuel line.

#### B) Heater ignites

##### 1) Shuts down at random

- Check:**
- Fuel metering pump quantity.
  - Possible overheat.
  - Control unit input voltage.

##### 2) Heater smokes and carbons up

- Check:**
- Exhaust pipe blocked.
  - Combustion air intake blocked.
  - Exhaust entering combustion air intake pipe.
  - Short cycling, rapid on/off operation.
  - Fuel system.
  - Fuel metering pump quantity.
  - Motor rpm.

## 4. SELF DIAGNOSTICS

The heater is equipped with self diagnostic capability. To retrieve information on the heaters last 5 faults, a retrieval device is required (part # CA1 05 020).

- Connect the fault code retrieval device as shown in **Figure IV A**.

**Figure IV A**

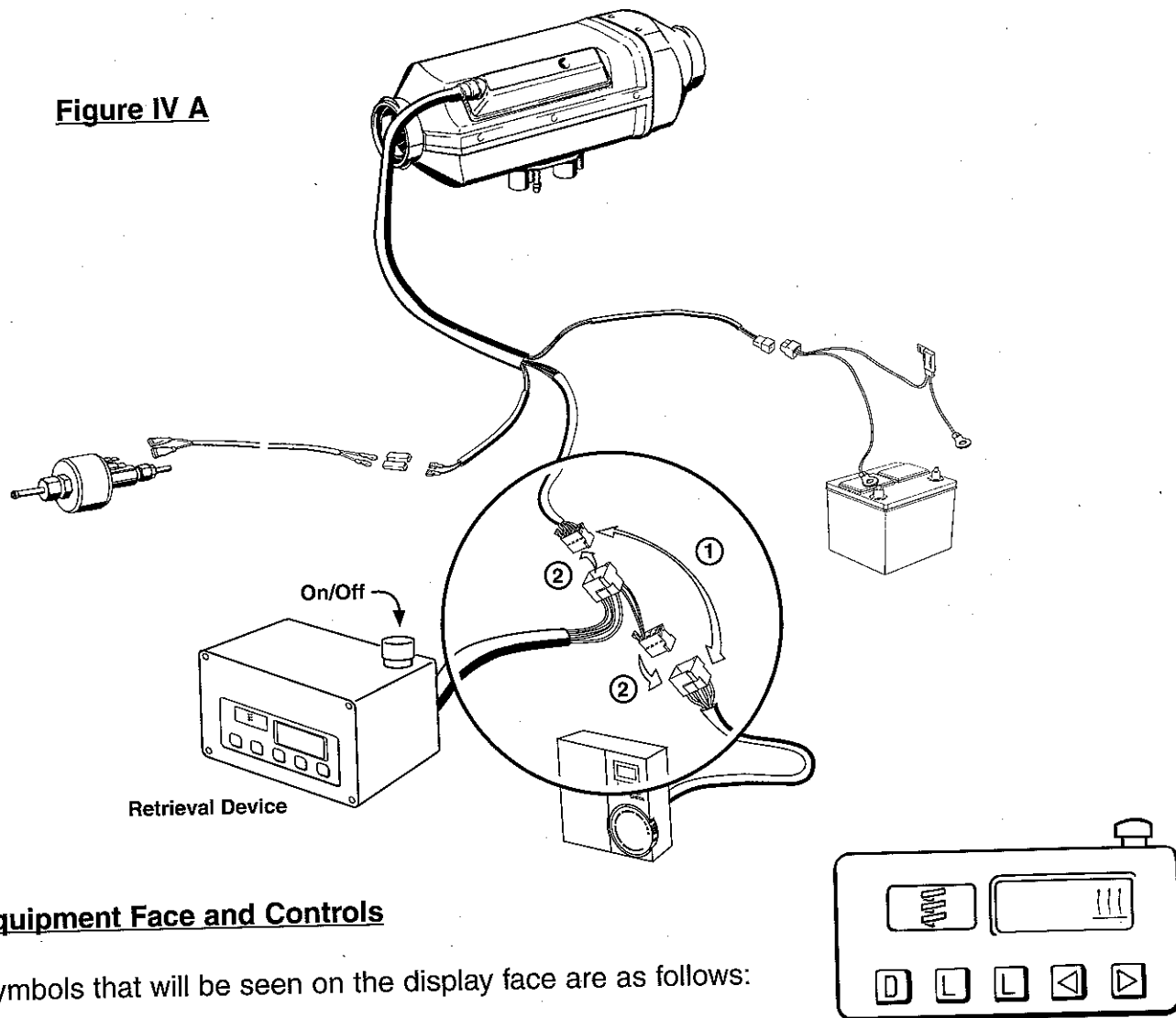

### Equipment Face and Controls

Symbols that will be seen on the display face are as follows:

**AF** Actual fault.

**F1-F5** Up to five stored faults can be accessed. The AF and F1 are the same number.



This sign is displayed when the heater is in operation.

**DIAG**

The word Diag(nostic) will come on when the diagnostic number is requested.

**000**

Three digit diagnostic fault code number.

- Switch the fault code retrieval device on and wait 10 seconds.
- Press the "D" button.
- Wait 3-5 seconds for the current fault code to appear (AF).
- To review the previous faults use the arrow buttons (F1=Most Recent, F5=Oldest).
- To erase the faults that are in memory press both "L" keys at the same time.
- Consult the fault code chart for code number descriptions.

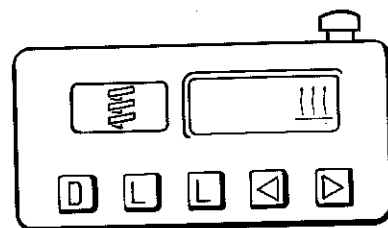





**Note:** If there are no heater faults, the heater will go through a normal start cycle and regulate based on thermostat setting.

<b>Fault Code</b>	<b>Fault Description</b>	<b>Causes / Repair</b>
000	Normal Operation	
001	Warning - overvoltage	Check vehicle charging system.
002	Warning - undervoltage	Check batteries and connections.
004	Warning - short in blower signal	Check for short between pin 1 to blower relay. If no short exists replace control unit.
005	Warning - short circuit in anti-theft alarm output	Check for short between pin 2 and alarm relay.
009	TRS - shut down	Check for change of signal from (+) to (-) at pin 10 or a (+) signal at pin 12.
010	Overvoltage	Check voltage between terminals 9 and 11. This must be less than 15.9 volts (15.2 volts with glow plug on). Check vehicle charging system.
011	Undervoltage shut down	Check voltage between control unit pins 9 and 11. This must be greater than 10.5 volts (9.5 volts with glow plug on). Check batteries and connections.
012	Overheat	Check for possible causes of overheat. Check overheat switch resistance values (see component value chart).
013	Overheat at flame sensor	Flame sensor senses temperature above 340°C (resistance value above 2270 Ω ). Check flame sensor resistance values and overheat switch resistance values (see component value chart).
015	Too many overheats	Control unit limits heater to 3 consecutive overheats (fault code 12, 13). Remove cause of overheat. Reset control unit using control unit tester or fault code retrieval device to unlock control unit.

Fault Code	Fault Description	Causes / Repair
020	Open circuit - glow plug	Check glow plug for break in coils. Check resistance across glow plug leads (1-2 $\Omega$ ). Check for continuity between pins 6 and 9. If aforementioned checks okay, replace control unit.
021	Short circuit - glow plug	Check glow plug for short across coils. Check pin 6 to glow plug for short. If glow plug short detected, replace glow plug. If aforementioned checks okay replace control unit.
025	Diagnostics output short	Check for short between pin 4 and diagnostics output connection.
033	Burner motor speed deviation	Motor speed varies from specification by more than 10% for longer than 30 seconds. If too slow, check for restriction, and check for short in motor circuit or control unit. If none found, replace blower. If too fast, check for damage to magnetic sensor control on control unit. Replace blower motor if damaged. Replace control unit otherwise.
047	Short circuit - fuel metering pump	Check for short between pin 3 and fuel metering pump. Test fuel metering pump.
048	Open circuit - fuel metering pump	Check for open circuit between pins 3 and fuel metering pump.
050	Too many no start attempts	Control unit restricts heater to 10 start attempts (20 starts if no flame is detected during start attempts). Check fuel, glow plug, combustion air and exhaust flow. Use control unit tester or fault code retrieval device to unlock control unit.
051	Faulty flame recognition	Allow heater to cool 15 minutes then try restart. Check flame sensor resistance value.
052	No start safety time exceeded	No flame detected on start attempt. Temperature at flame sensor $<100^{\circ}\text{C}$ (1380 $\Omega$ ). Check flame sensor resistance values. Check fuel, glow plug, combustion air and exhaust flows.

Fault Code	Fault Description	Causes / Repair
053	Flame cutout in boost mode	Heater has started successfully the flame has extinguished. Check fuel supply. Check combustion air and exhaust flow. Check flame sensor resistance value.
054 055 056	Flame cutout in high mode Flame cutout in medium mode Flame cutout in low mode	Heater has started successfully the flame has extinguished. Check fuel supply. Check combustion air and exhaust flow. Check flame sensor resistance value.
060 061	Open circuit - external temperature sensor Short circuit - external temperature sensor	Temperature sensor detects a value beyond it's range. Check connections. Check sensor resistance between pins 8 and 13. >2800 $\Omega$ - open <280 $\Omega$ - short
062 063	Open circuit - set point potentiometer (control switch) Short circuit - set point potentiometer (control switch)	Potentiometer values outside of range Check resistance between pins 7 and 13. >2800 $\Omega$ - open <280 $\Omega$ - short Normal range 1750 - 2080 $\Omega$ (+/- 80).
064 065 071	Open circuit - flame sensor Short circuit - flame sensor Open circuit - overheat sensor	Sensor is sensing value outside of range >3200 $\Omega$ - open <200 $\Omega$ - short
090	Control unit defect	Internal failure. Replace control unit.
091	External voltage disturbance	Check vehicle charging system.
092 093 094	Control unit defective	Internal failure. Replace control unit.
096	Control unit defective (internal temperature sensor)	Internal failure. Replace control unit or use external sensor.
097	Control unit defective (power failure)	Internal failure. Replace control unit.

## 5. FUEL QUANTITY TEST

The fuel quantity should be tested if the heater has difficulty starting or maintaining a flame:

### A) Preparation

- Detach the fuel line from the heater.
- Insert the fuel line into a measuring glass (10 cc). **(Figure IV B)**
- Switch the heater on and allow fuel system to bleed out air for approx. 20 seconds.
- Switch the heater off and empty the measuring glass.

### B) Measurement

- Switch heater on.
- Hold the fuel line in the measuring glass while fuel is being delivered.
- The pump will stop automatically after delivering fuel for 90 seconds.
- Once fuel pump stops, switch heater off.

### C) Evaluation

- Read the amount of fuel delivered.
- Fuel quantity should be between 3.4ml and 4.65ml.
- If the fuel quantity is outside this range, check for and remove any restriction in fuel system or replace the fuel metering pump. (Check screen in suction side of pump)

**Note:** The fuel quantity is not affected by voltage variances.

**Figure IV B**

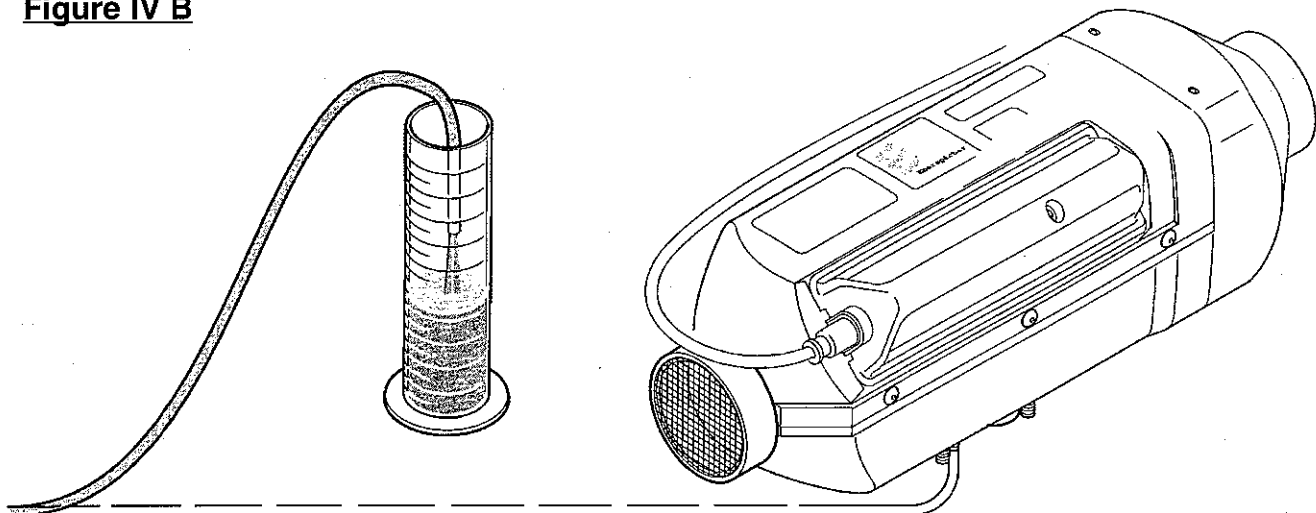



## 6. COMPONENT SPECIFICATION CHART

Component values given are reference numbers only (at room temperature). Actual component values may vary  $\pm 10\%$ .

### A. Resistance Values

Component	Resistance	Location	Wire Colors
Glow Plug	1 $\Omega$	Glow Plug	White, Brown
Motor	.5 $\Omega$	From Control Unit	Black, Brown
Flame Sensor	1.1 K $\Omega$	From Control Unit	Blue, Blue
Overheat Sensor	1.1 K $\Omega$	From Control Unit	Blue, Blue
Fuel Pump	10.0 $\Omega$	Fuel Metering Pump	Grn/Brn,Grn
Rheostat (Range)	1.8-2.2 K $\Omega$	Thermostat Pins 1,2	Brn/Wt,Gr/Rd
Temperature Sensor (Range)	1.8-2.2 K $\Omega$	Thermostat Pins 1,T	Brn/Wt ,Grey

### B. Motor Speeds

Boost	5,000 RPM
High	4,400 RPM
Medium	3,000 RPM
Low	3,000 RPM
Recirculation	1,000 RPM (when using internal temperature sensor)

### C. Exhaust Gas

- CO<sub>2</sub> concentration in exhaust gas when heater is running in High heat mode 6-10%.
- Smoke test value from exhaust gas when heater is running in High heat mode <4.

## 7. REPAIR STEPS

**Caution:** Remove power from the heater prior to any disassembly by unplugging main connection or removing main fuse.

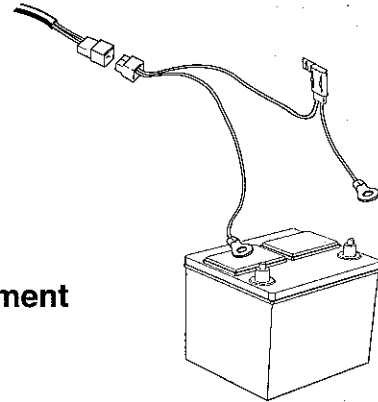

- A. Glow Plug Removal, Inspection and Replacement
- B. Atomizer Screen Removal, Inspection and Replacement
- C. Control Unit Removal and Replacement
- D. Heater Casing Disassembly
- E. Overheat Sensor Replacement
- F. Flame Sensor Replacement
- G. Blower Removal and Replacement
- H. Heat Exchanger Cleaning and Inspection

### A. Glow Plug Removal, Inspection and Replacement

- Remove glow plug connector. (Figure IV C)
- Remove glow plug.
- Inspect coils for carbon build up, breaks or metal fatigue.
- Clean or replace if necessary.
- Re-install in reverse order using a new gasket.

**Figure IV C**

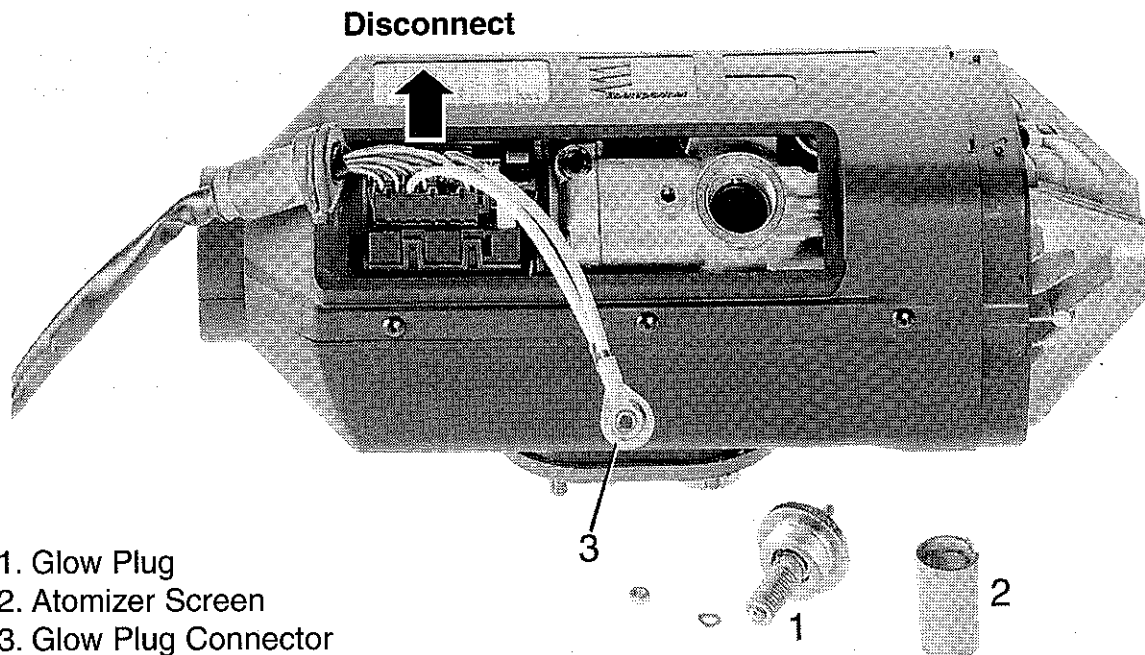

## B. Atomizer Screen Removal, Inspection and Replacement

- Remove atomizing screen using the metal tab and a pair of pliers.
- Clean screen using varsol, brass wire brush and compressed air.
- Inspect screen for deterioration and replace if necessary.
- Clean the glow plug chamber to remove carbon build up.
- Ensure air vent hole and fuel port are clear.
- Re-install fuel screen. **Figure IV D**

**Note:** Ensure seam of screen and tab do not block the air vent hole or fuel port.

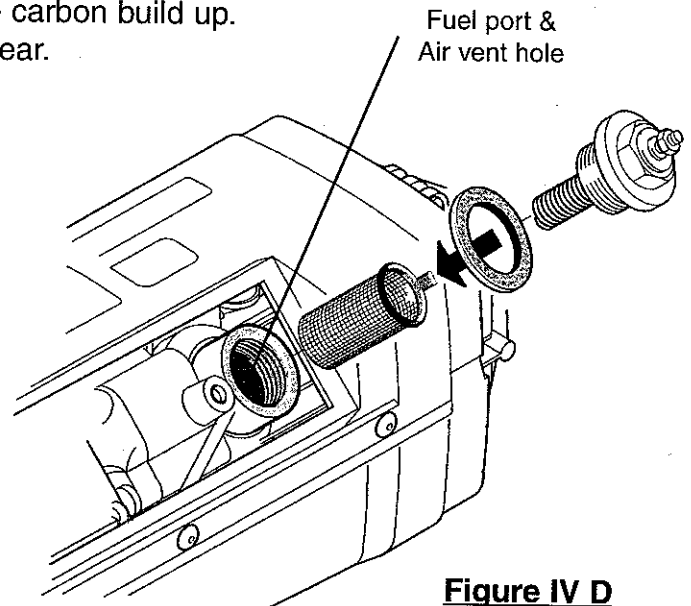

**Figure IV D**

## C. Control Unit Removal and Replacement

- Unplug main harness and motor connectors. (1)
- To remove Control Unit, unlock and slide out. (2)
- Unplug overheat switch and flame sensor connectors. (3)
- Re-install in reverse order.

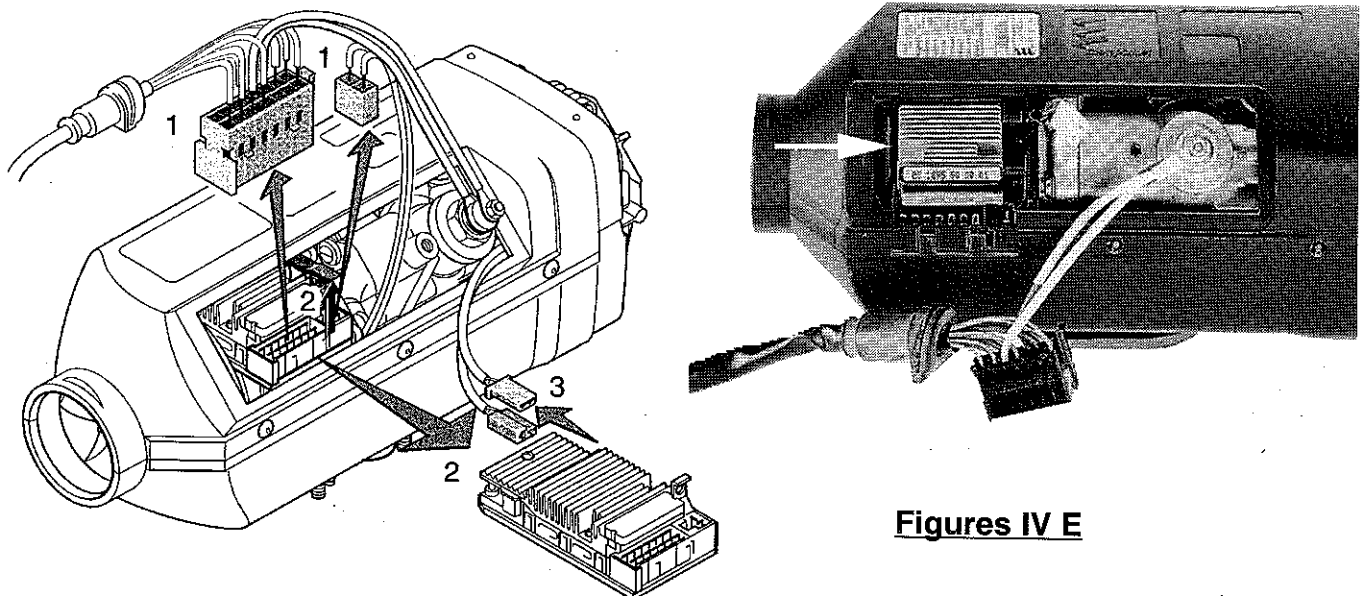

**Figures IV E**

## D. Heater Casing Disassembly

- Remove internal hex screw and cap. **Figure IV F**
- Pry off air outlet hood using a flat screw driver.
- Remove rivets by punching center pin through and prying out base. **Figure IV G**
- Remove rubber seal at base of heat exchanger.
- Separate outer casing.
- Re-assemble in reverse order using new rivets. **Figure IV H**

**Figure IV F**

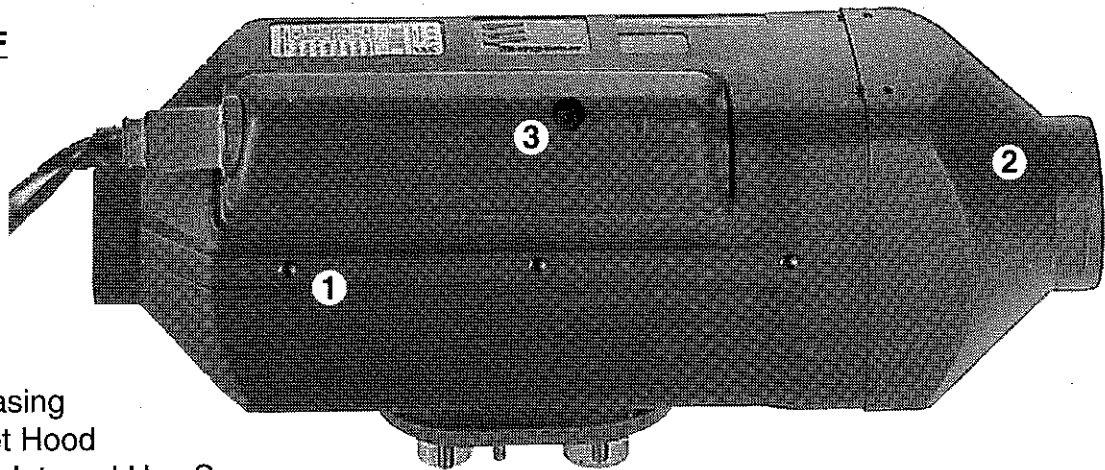

1. Outer Casing
2. Air Outlet Hood
3. Cap with Internal Hex Screw

**Figure IV G**

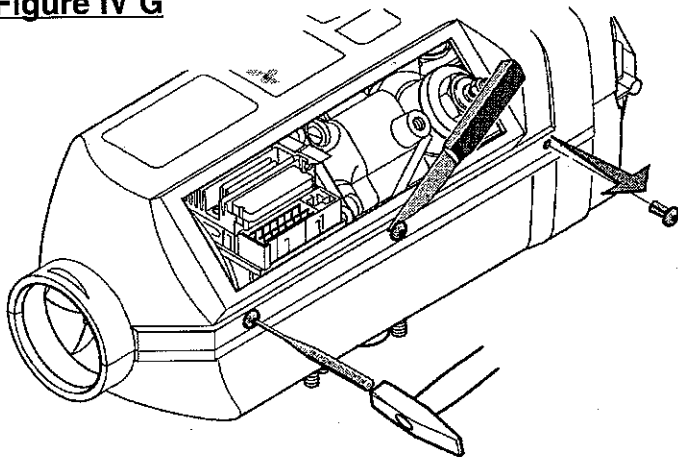

**Figure IV H**

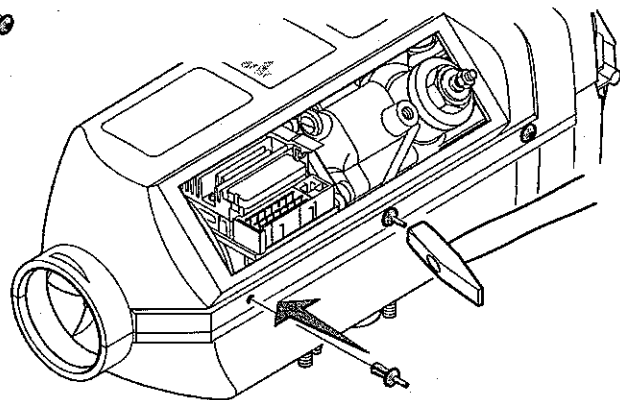

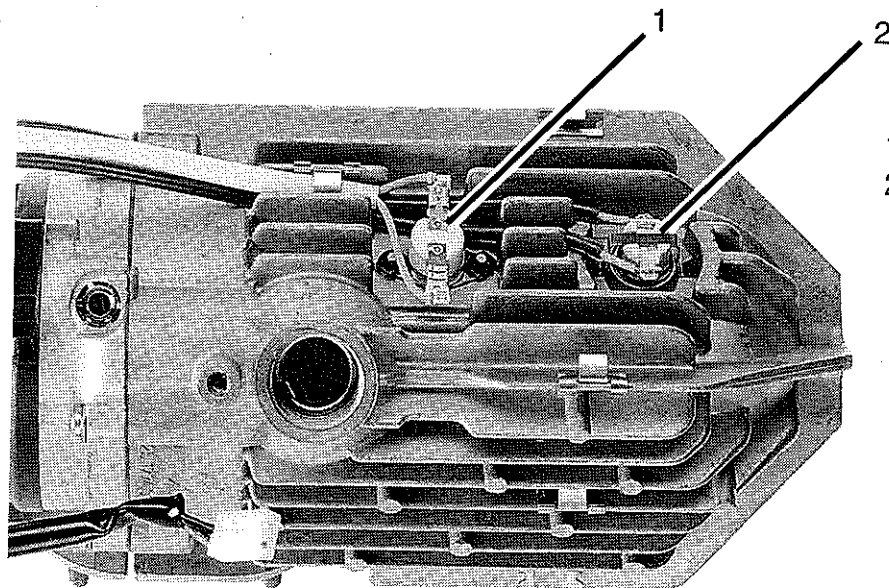
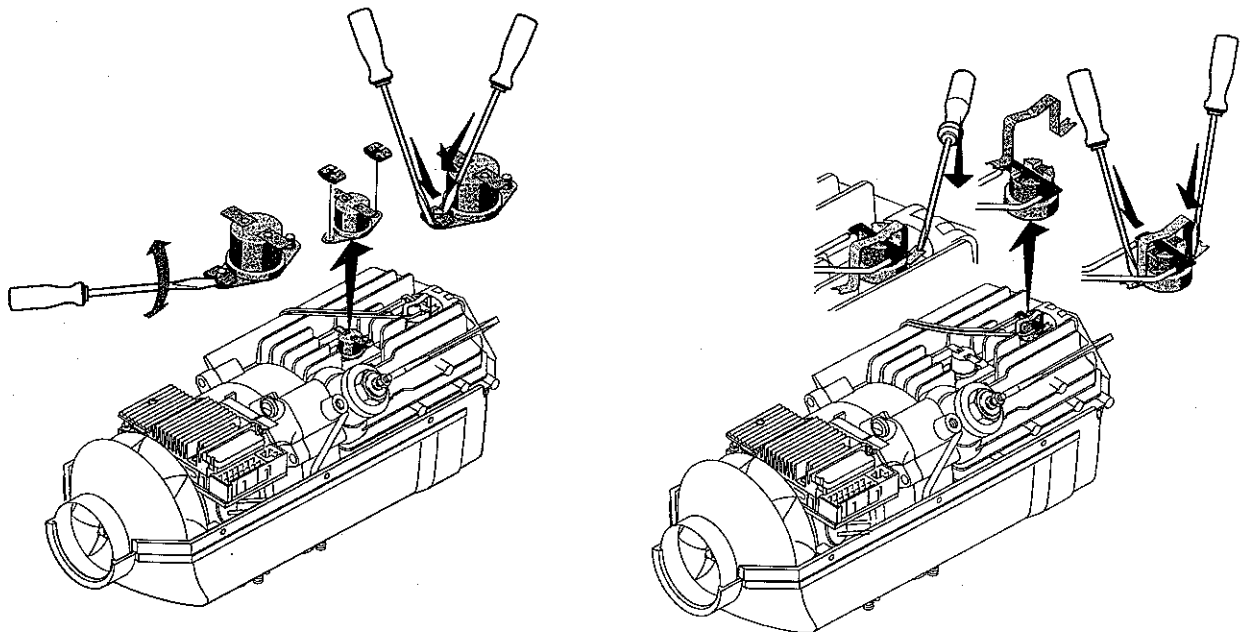

**Figure IV I**

1. Overheat Sensor
2. Flame Sensor

### E. Overheat Sensor Replacement

- Using a small flat screw driver, pry off holding clips. **Figure IV J**
- Lift sensor from mounting studs.
- Install replacement sensor using new holding clips.
- Ensure the sensor is securely mounted against heat exchanger.



### F. Flame Sensor Replacement

- Using a small flat screw driver, pry off holding spring. **Figure IV K**
- Remove spring and flame sensor.
- Install replacement sensor using a new mounting spring.
- Ensure the sensor is securely mounted against heat exchanger.

## G. Blower Removal and Replacement

- Remove four mounting screws.
- Separate blower from heat exchanger. **Figure IV L**
- Re-assemble using new gasket.

**Figure IV L**

1. Blower
2. Heat Exchanger
3. Gasket

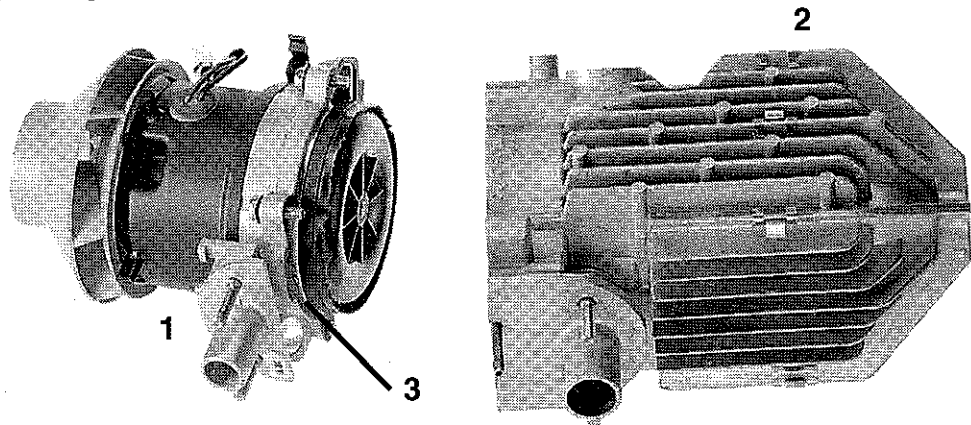

## H. Heat Exchanger Cleaning and Inspection

- Remove two mounting screws and baffle plate. **Figures IV M**
- Remove and replace gasket.
- Clean excessive carbon from inside heat exchanger using a brass wire brush, varsol and compressed air.
- Inspect felt ring and replace if damaged.
- Re-assemble in reverse order using new gaskets.

**Figures IV M**

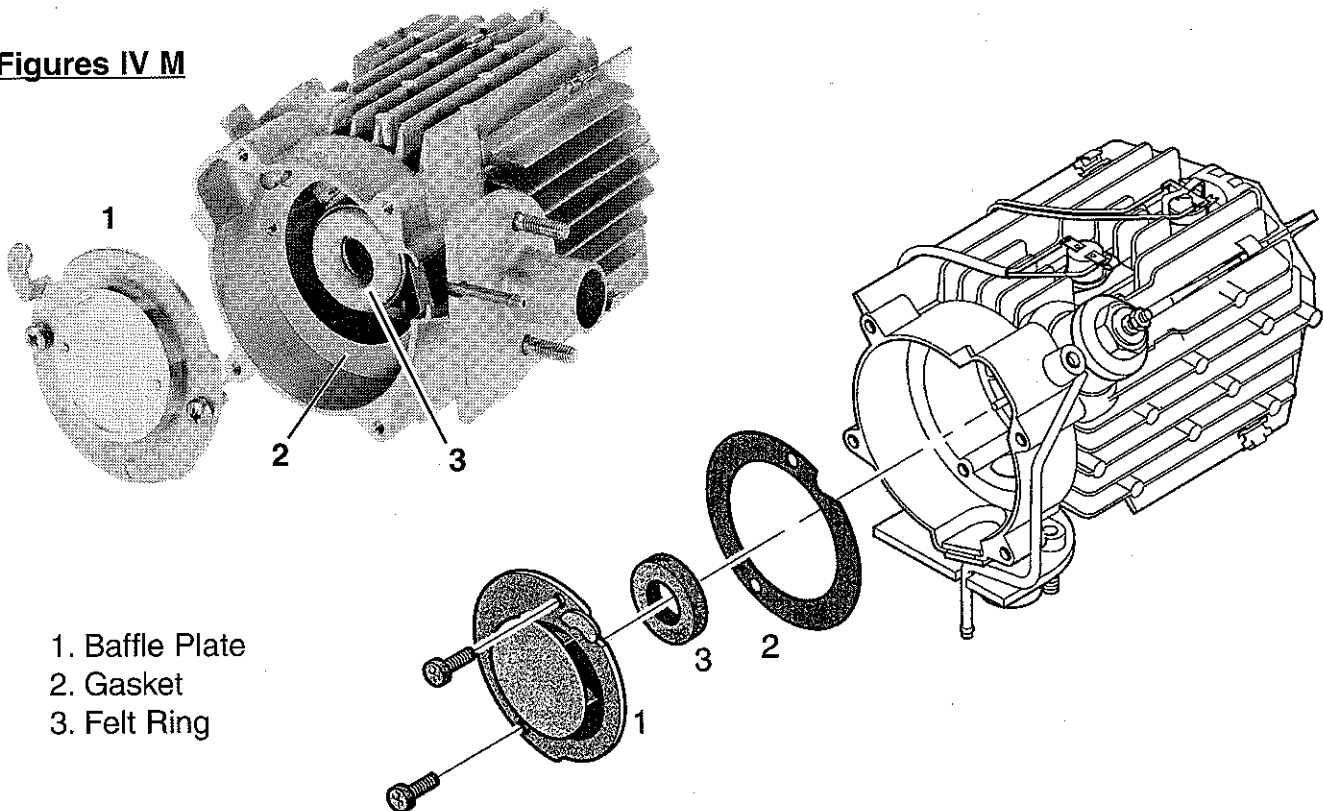

1. Baffle Plate
2. Gasket
3. Felt Ring

# D1LCcompact

## SERVICE PARTS DIAGRAM

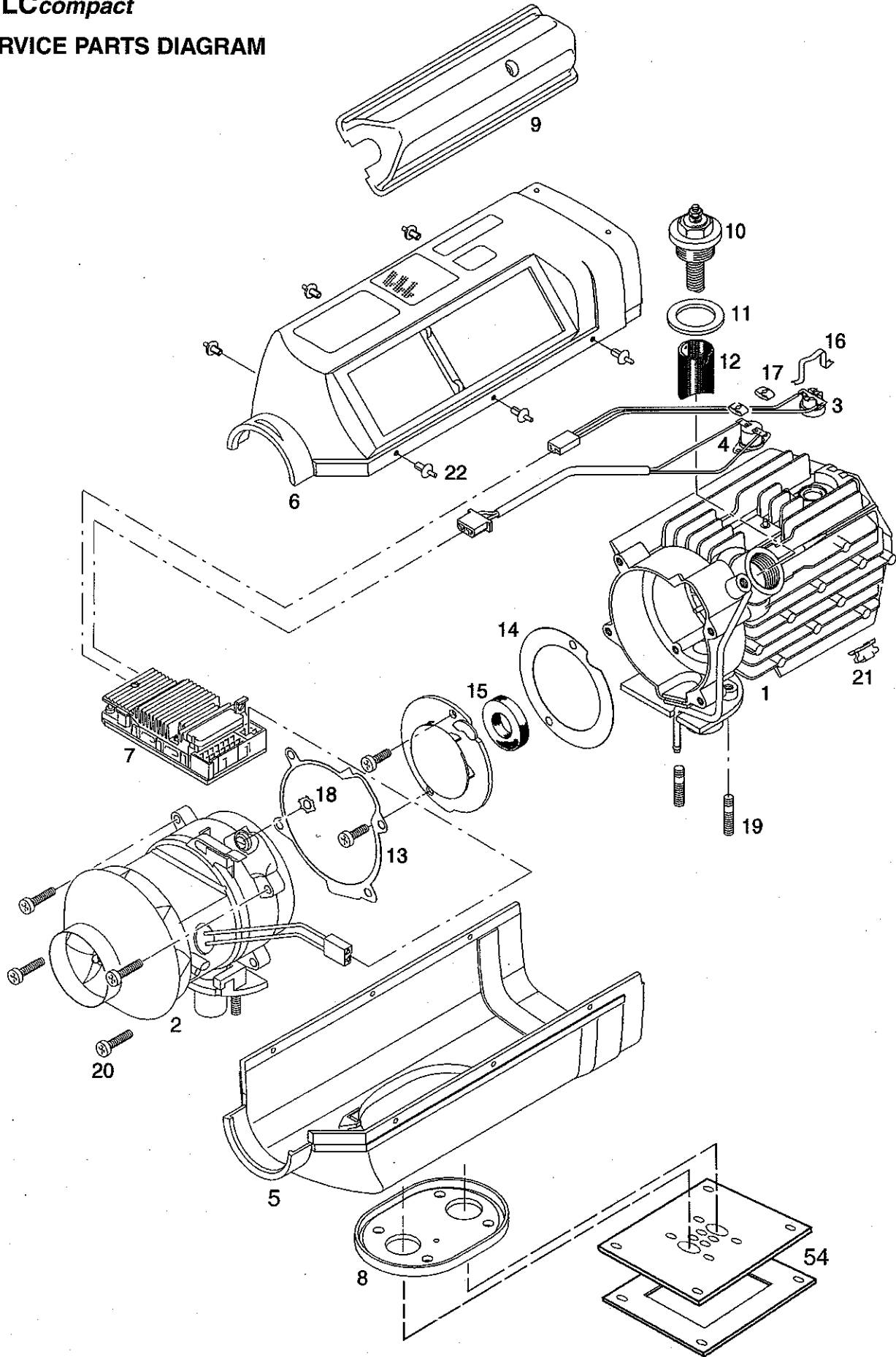

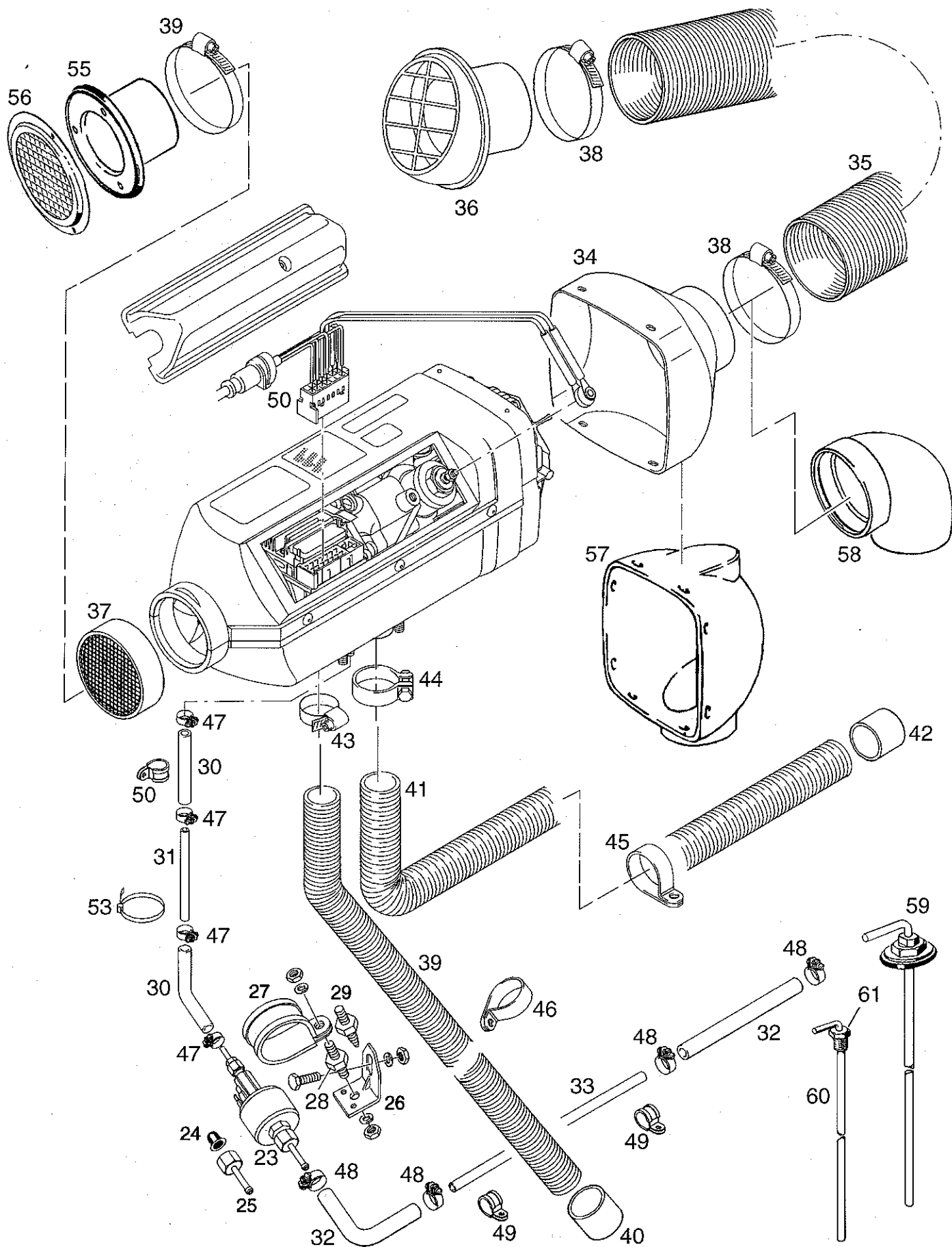

PARTS continued.

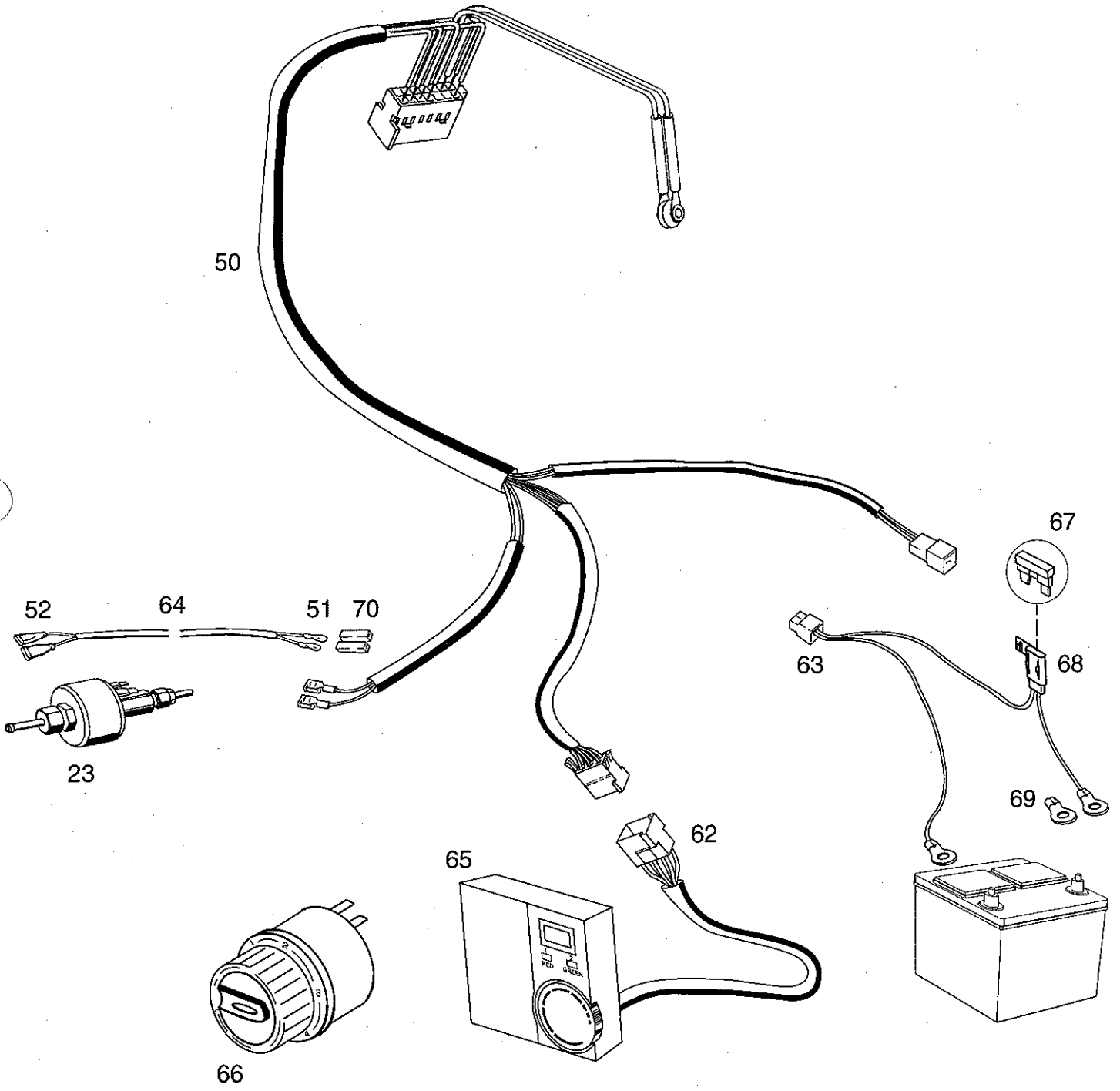

**NOTES**



# D1LCcompact PARTS LIST



Ref. No.	Description	Part Number	Model #	
			25 1895	25 1896
1	Heat exchanger	25 1774 99 06 00	.	.
2	Combustion air blower	12 Volt 25 1895 99 20 00 24 Volt 25 1896 99 20 00	.	.
3	Flame sensor	25 1895 99 35 00	.	.
4	Safety thermal sensor	25 1895 41 00 00	.	.
5	Lower half of casing	25 1895 01 01 00	.	.
6	Upper half of casing	25 1895 01 06 00	.	.
7	Control unit	12 Volt 25 1895 50 00 13 24 Volt 25 1896 50 00 10	.	.
8	Flange seal	25 1774 01 00 02	.	.
9	Cable cover	25 1895 01 02 00	.	.
10	Glow plug	12 Volt 25 1830 01 01 00 24 Volt 25 1831 01 01 00	.	.
11	Seal ring	25 1830 01 01 01	.	.
12	Glow plug screen	25 1688 06 04 00	.	.
13	Gasket, blower	25 1688 01 00 06	.	.
14	Gasket, heat exchanger	25 1688 06 00 03	.	.
15	Seal ring, heat exchanger	25 1688 06 00 06	.	.
16	Spring, flame sensor	25 1895 01 00 03	.	.
17	Clip, safety switch	171 42 080	.	.
18	Serrated ring	171 19 254	.	.

Ref. No.	Description	Part Number	25 1895	25 1896
19	Grub screw M6x20 DIN 835	106 10 022	•	•
20	Fillister head bolt M5x20	103 10 461	•	•
21	U-Clip	25 1688 01 00 03	•	•
22	Rivet, black plastic	131 31 051	•	•
23	Fuel metering pump	12 Volt 25 1830 45 00 00	•	•
		24 Volt 25 1831 45 00 00		•
24	Fuel screen	20 1312 00 00 06	•	•
25	Hose connection	20 1621 45 00 00	•	•
26	Angle bracket	20 1348 03 00 02	•	•
27	Clamp for fuel metering pump	152 00 144	•	•
28	Rubber mount 6mm	20 1185 00 00 01	•	•
29	Rubber mount	20 1673 80 01 01	•	•
30	Fuel hose 3.5mm ID	360 75 300	•	•
31	Plastic fuel line 1.5mm ID	090 31 118	•	•
32	Fuel hose 5mm ID	360 75 350	•	•
33	Plastic fuel line 2mm ID	090 31 125	•	•
34	Straight outlet hood 60mm	25 1688 80 03 00	•	•
35	Flexible air hose 60mm ID	10 2114 31 00 00	•	•
36	Deflector 60mm	20 1577 89 06 00	•	•
37	Safety screen	25 1688 80 06 00	•	•
38	Clamp 46mm-70mm	CA1 10 047	•	•
39	Air intake hose 20mm ID	360 00 099	•	•



Ref. No.	Description	Part Number	25 1895	25 1896
40	End sleeve with crossbar	25 1688 80 12 01		
41	Flexible exhaust tube 24mm ID	360 61 299	•	•
42	End sleeve 24mm	25 1482 80 00 01	•	•
43	Clamp 16mm-25mm	10 2064 01 60 25	•	•
44	Clamp 26mm	152 61 102	•	•
45	"C" Clamp 28mm	152 10 051	•	•
46	"C" Clamp 25mm	152 10 048	•	•
47	Clamp 9mm	10 2063 00 90 98	•	•
48	Clamp 11mm	10 2063 01 10 98	•	•
49	"C" Clamp 10mm	152 00 139	•	•
50	Main harness	CA160 105	•	•
51	Terminal 18 AWG	CA1 90 060	•	•
52	Rubber boot	320 31 120	•	•
53	Cable ties 197mm	CA1 00 005	•	•
54	Mounting plate with hardware & seal	CA0 00 019	•	•
55	Flange for outlet grill	20 1577 89 06 01	•	•
56	Plastic Screen 60mm	22 1000 01 00 01	•	•
* 57	90° Air outlet hood	25 1688 89 01 01	•	•
* 58	90° Bend	25 1688 89 00 01	•	•
59	Standard fuel pick up pipe 2mm	CA0 12 056	•	•
* 60	Fuel pick up pipe (Compression fitting type)	CA0 12 042	•	•

Ref. No.	Description	Part Number	25 1895	25 1896
* 61	Compression fittings 1/4" NPT 3/8" NPT 1/2" NPT	CA0 12 044 CA0 00 031 CA0 12 005	• • •	• • •
62	Switch/ Thermostat harness (15')	CA1 70 111	•	•
63	Power harness (13')	CA1 65 106	•	•
64	Fuel metering pump harness (20')	CA1 75 015	•	•
65	Thermostat	12 Volt 301 00 154 24 Volt 301 00 153	• •	• •
* 66	Operating switch (rotary)	12 Volt 25 1895 71 00 00 24 Volt 25 1896 71 00 00	• •	• •
67	Blade fuse (25A)	204 00 089	•	•
68	Fuse holder with terminals	CA1 07 001	•	•
69	3/8" Ring terminal 10-12G	CA1 90 014	•	•
70	Plug & socket connector	206 00 040	•	•
71	Operator's guide (not shown)	615 101 0296	•	•
72	Operator's tape (not shown)	625 101 0893	•	•
73	D1LCc North American manual (not shown)	610 101 0396	•	•
74	Fault code retrieval device (shown pg. 21)	CA1 05 020	•	•
*	indicates optional features			

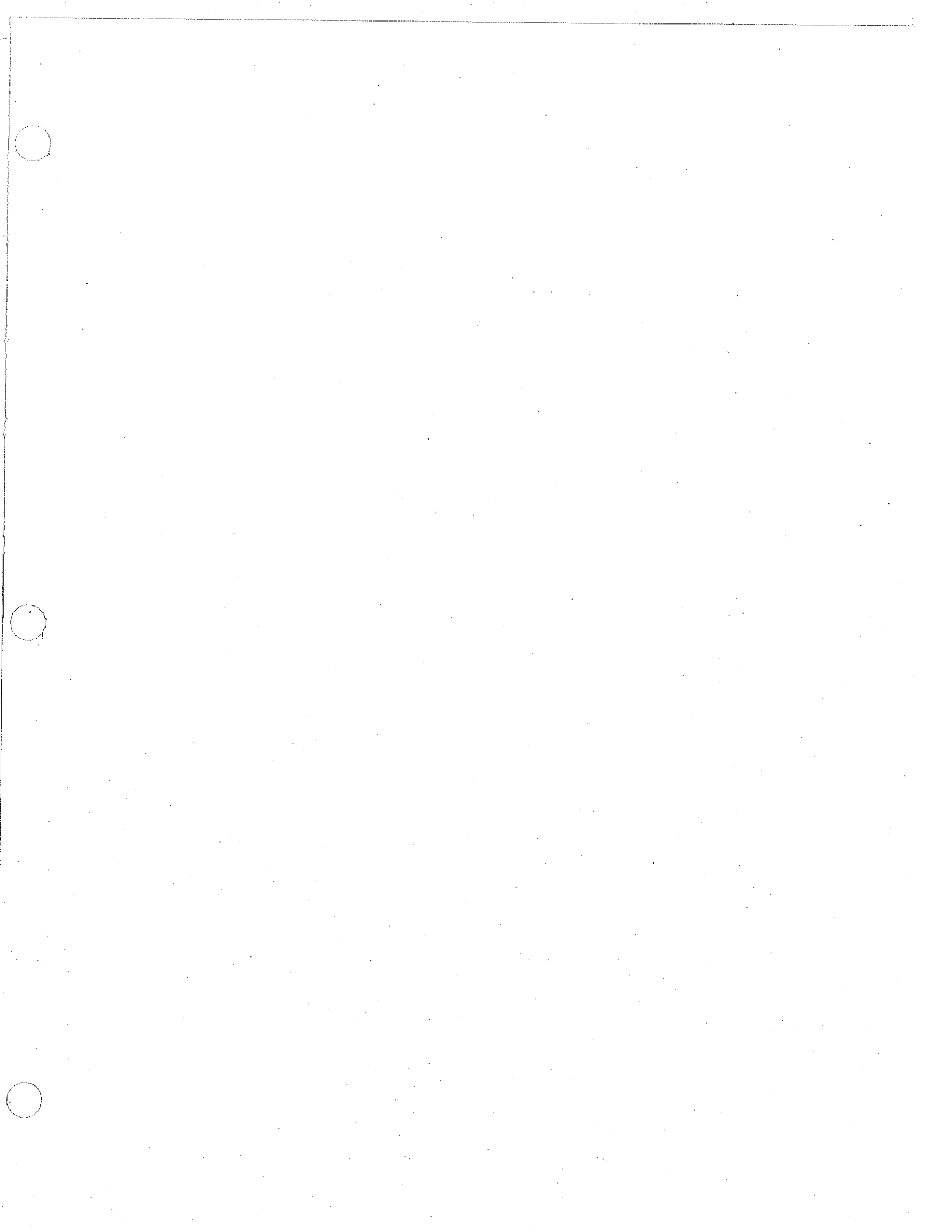

1st. Printing -March 1996

Printed in Canada

P/N: 610-101-0396

**ESPAR PRODUCTS, INC.**

6435 Kestrel Road  
Mississauga, Ontario  
Canada L5T 1Z8

Canada:	905-670-0960
	800-668-5676
U.S.:	800-387-4800
Fax:	905-670-0728

A member of the Worldwide **Eberspächer** Group of Companies