

# Air heater

## B 1 L C compact / D 1 L C compact

Troubleshooting and repair instructions



Eberspächer®

J. Eberspächer  
GmbH & Co.  
Eberspächerstr. 24  
D-73730 Esslingen

Telefon (zentral)  
(0711) 939-00  
Telefax  
(0711) 939-0500  
[www.eberspaecher.de](http://www.eberspaecher.de)

These troubleshooting and repair instructions are valid for the following heater versions

Heater-version	Glow plug (-) pulsed	(+) pulsed / current regulator	(+) pulsed
<b>B 1 L C compact</b>	20 1748 01 - 12 Volt	20 1761 01 - 12 Volt	20 1766 01 - 12 Volt
<b>D 1 L C compact</b>	25 1895 01 - 12 Volt 25 1896 01 - 24 Volt 25 1924 01 - 24 Volt	25 1965 01 - 12 Volt 25 1966 01 - 24 Volt 25 1957 01 - 12 Volt 25 1971 01 - 24 Volt	25 1976 01 - 12 Volt 25 1977 01 - 24 Volt 25 1979 01 - 12 Volt 25 1978 01 - 24 Volt

Contents	Page
Sectional view .....	2
Functional description .....	3
Specifications .....	4
Check values .....	5
First check the following if faults occur .....	5
Fault diagnosis using the timer module .....	6
Checking the operating unit using the tester .....	7
Fault codes, fault descriptions, remarks / remedial action .....	8 - 10
Wiring diagram of heater .....	11 - 14
Wiring diagram of control elements .....	15
Repair instructions .....	16 - 20
Fuel quantity measurement .....	21

**Sectional view** (the version without current regulator is represented)

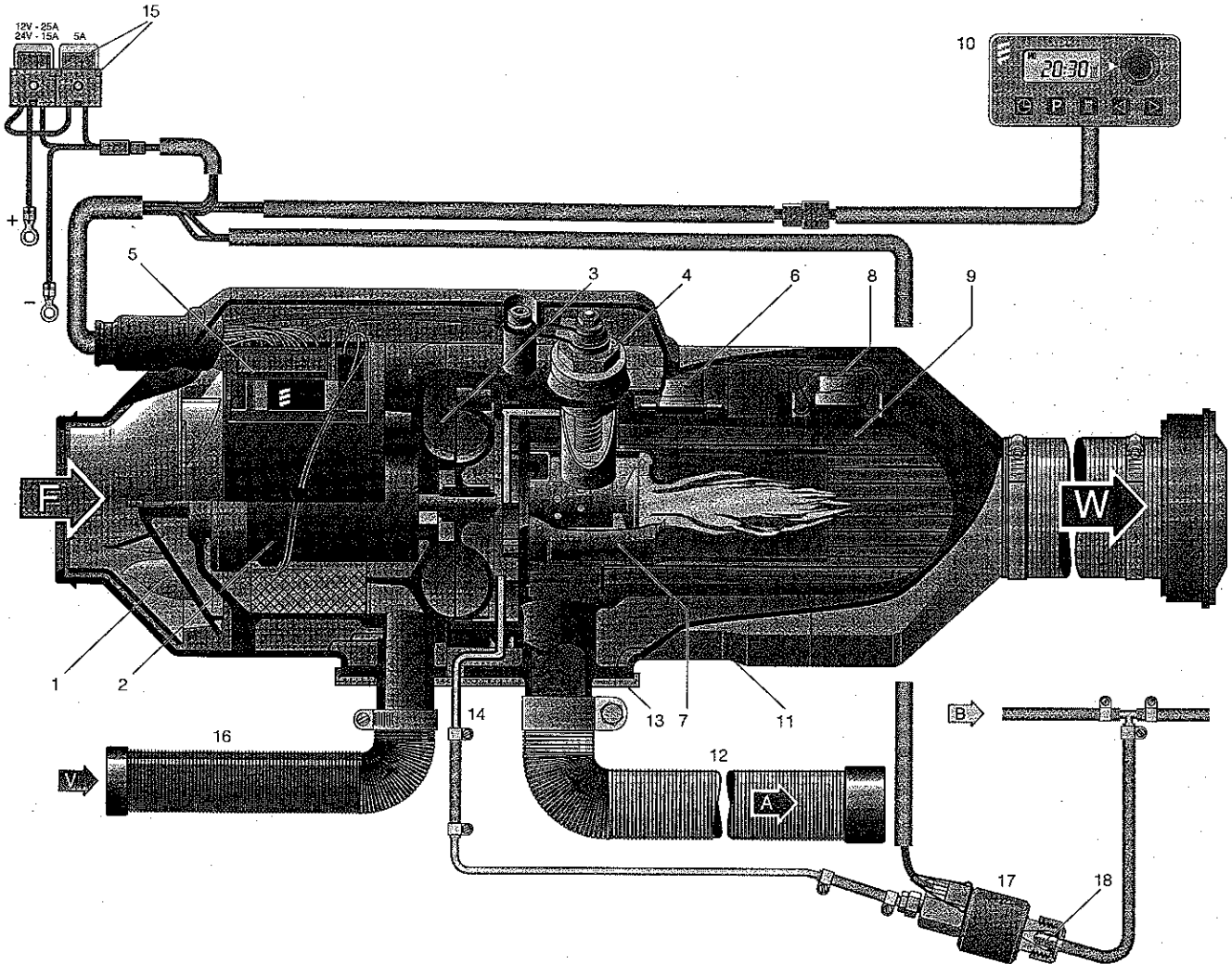

- |    |   |    |                                     |
|----|---|----|-------------------------------------|
| 1  | Fresh air blower wheel                        | 14 | Fuel connection                     |
| 2  | Electric motor                                | 15 | Main fuses                          |
| 3  | Combustion air blower wheel                   | 16 | Combustion air piping               |
| 4  | Glow plug                                     | 17 | Metering pump                       |
| 5  | Electronic control unit                       | 18 | Screen - installed in metering pump |
| 6  | Safety thermal cutout switch /overheat sensor | A  | Exhaust gas                         |
| 7  | Combustion chamber                            | B  | Fuel                                |
| 8  | Flame sensor                                  | F  | Fresh air                           |
| 9  | Heat exchanger                                | V  | Combustion air                      |
| 10 | Timer module                                  | W  | Hot air                             |
| 11 | Outer casing                                  |    |                                     |
| 12 | Exhaust pipe                                  |    |                                     |
| 13 | Flange seal                                   |    |                                     |



## Functional description

### Switch-on

The status display or green pilot light comes on when the heater is switched on. The glow plug is switched on. The blower starts up at a low speed.

#### Note:

If the heat exchanger still contains residual heat, only the blower runs (cold-blowing phase). The start-up procedure commences after the residual heat has dissipated.

### Start-up procedure

Fuel feed starts after approx. 45 seconds. The fuel/air mixture ignites. Blower speed and fuel feed are increased continuously. Once a flame has been detected and the combustion process has stabilized, the glow plug is switched off. The heater is heated up rapidly in the „POWER“ setting at maximum heat flow until the heat exchanger has reached its operating temperature.

#### Note:

The duration of max. heat flow in the „POWER“ setting is temperature-dependent.

### Control during heating operation

During heating operation, the room temperature or the intake heating air temperature is measured continuously and compared with the temperature set at the operating unit.

If the operating temperature of the intake heating air exceeds the desired room temperature, the heater switches to the „LOW“ setting and continues to run at a low blower motor speed.

If the heating capacity in the „LOW“ setting is insufficient, the heater switches to the „MEDIUM“ setting.

The blower continues to run at a low speed.

In most cases, the „LOW-MEDIUM-LOW“ control sequence at low blower speed will supply the required heat. If the „MEDIUM“ setting is not sufficient, the heater switches back to the „HIGH“ setting.

This again requires full blower speed.

If in special cases an even lower heating capacity is required than the heater delivers in the „LOW“ setting, the heater switches to the „OFF“ setting.

Once the normal afterrun period has elapsed, the heater is constantly after-ventilated at minimum blower speed (during recirculated-air operation only) until the heater is restarted.

Restart is generally in the „MEDIUM“ setting at a low blower motor speed.

### Switch-off

When the heater is switched off, the status display or green pilot light goes out and fuel feed is shut off. The blower continues to run to cool down the heater. The glow plug remains switched on for another 30 seconds to clear the heater of combustion residues.

#### Note:

If no fuel feed took place during the start-up procedure or if the heater is in the „OFF“ setting, the heater is switched off immediately without afterrun.

### Controls and safety equipment

The flame is monitored by the flame sensor, and the max. permissible temperature by the safety thermal cutout switch or overheat sensor. They both influence the control unit, which shuts down the heater in the event of faults.

If the voltage drops below 10.5 or 21 V (depending on version) or rises above 15.9 or 31.8 V (depending on version), a fault shutdown is activated.

If the glow plug is defective or an electrical lead running to the metering pump is broken, the heater does not start.

Blower motor speed is monitored continuously.

If the blower motor does not start or if the speed deviates by more than 10%, the unit cuts out after 30 seconds and a fault is displayed.

#### Please note!

When performing electric welding work on the vehicle, disconnect the plus terminal from the battery and connect to ground in order to protect the control unit.

## Specifications

Heating medium	Air
Heating capacity control	High/Medium/Low/Off
Fuel	Gasoline (commercially available) Diesel (commercially available)

Heating capacity <sup>1)</sup>	Power	High	Medium	Low	
		2200	1800	1200	850 W
Hot air throughput without backpressure <sup>1)</sup>	110	95	65	65 kg/h	
Fuel consumption <sup>1)</sup>	B 1 L C compact	0.30	0.24	0.16	0.12 l/h
	D 1 L C compact	0.27	0.21	0.14	0.10 l/h

Rated voltage	12 V	24 V
Operating range	10 to 14 V	20 to 28 V
Minimum voltage (An undervoltage safety device built into the control unit switches the heater off when the minimum voltage is not reached.)	10.5 V (9.5 V)	21 V (19 V)
Maximum voltage (An overvoltage safety device built into the control unit switches the heater off when the maximum voltage is exceeded.)	15.9 V (15.2 V)	31.8 V (30.4 V)

The values given in brackets apply when the glow plug is switched on.  
The voltages must be applied for longer than 20 sec.

Electric power consumption <sup>1)</sup>	at start	12 V	= 250 W
		24 V	= 210 W
	in operation	Power	= 30 W
		High	= 22 W
		Medium	= 10 W
		Low	= 8 W

Radio interference suppression level	3, additional radio interference suppression measures possible
--------------------------------------	--

Weight	approx. 3.5 kg
--------	----------------

Ambient temperature		Diesel	Gasoline
Heater	in operation	-40 °C to +70 °C	-40 °C to +50 °C
Heater	not in operation	-40 °C to +85 °C	-40 °C to +85 °C
Metering pump	in operation	-40 °C to +50 °C	-40 °C to +20 °C

<sup>1)</sup> At rated voltage Margin of error for all specifications ± 10 %



## Check values

### Motor speed

- Power 5000 rpm
- High 4400 rpm
- Medium 3000 rpm
- Low 2300 rpm
- "Off" control 1000 rpm with internal temperature sensor  
0 rpm with external temperature sensor

### Switching value

Safety thermal cutout switch 140 °C - 200 °C

### Exhaust emissions

CO<sub>2</sub> in exhaust gas in "High" setting 7 - 11 % by vol.  
Smoke spot number acc. to Bacharach < 4

### Resistance values

12 V metering pump approx. 10 Ω  
24 V metering pump approx. 36 Ω  
Glow plug 12 V approx. 0,6 Ω  
Glow plug 24 V approx. 2 Ω  
Operating unit / setpoint potentiometer 1750 - 2080 Ω (±80 Ω)

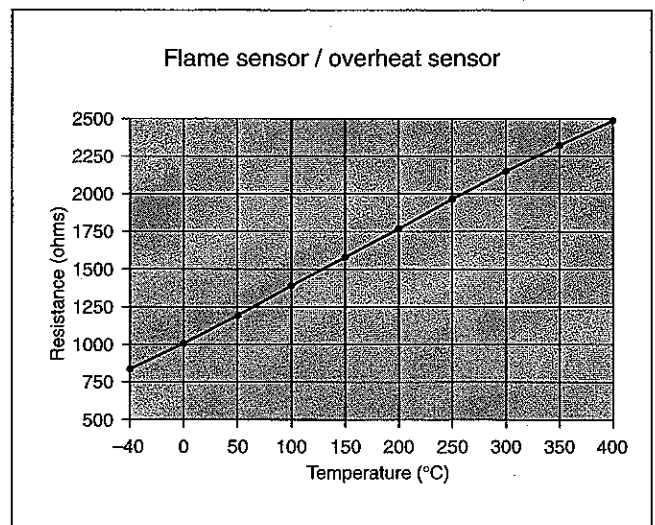
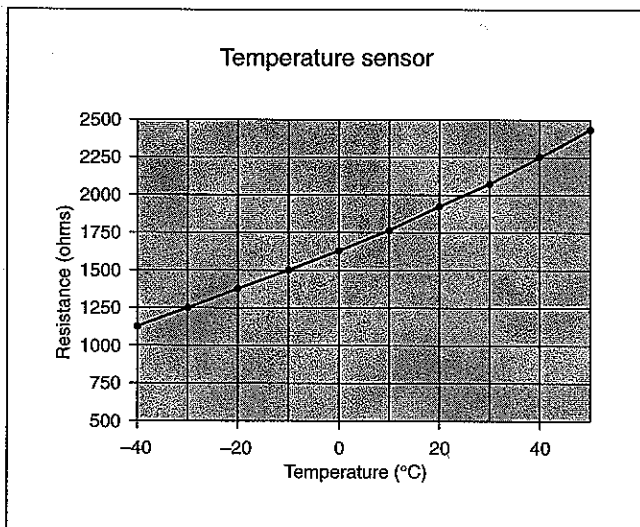

### First check for the following if faults occur

- Faulty wiring (short-circuits, interruption).
- Corroded contacts.
- Check fuses.
- Check electric leads, connections and terminals.
- Battery voltage less than 10 V / 20 V when starting heater.
- Mechanical damage of components.
- Check the fuel level.
- When making transition to winter operation: Is there still summer diesel in the fuel line?
- Check the exhaust and combustion air pipes.
- Are the heating air piping and intake air cleaner OK?

## Fault diagnosis using the timer module

Cat. No. Timer module display  22 1000 30 38 00

Cat. No. Timer module display  22 1000 30 40 00

If the control unit detects a fault when the heater is switched on or while the heater is in operation, the timer module indicates this by means of an F and as a 2-figure number within 15 sec.

Reading on display, e.g. **F64** (current fault) and flashing heating symbol

Fault codes, fault descriptions, remarks/remedial action are described on pages 9 to 11.

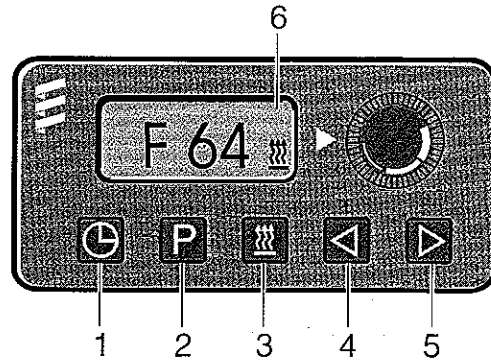





- |   |            |   |                               |
|---|------------|---|-------------------------------|
| 1 | Clock time | 2 | Preset                        |
| 3 | Heating    | 4 | Backward                      |
| 5 | Forwards   | 6 | Display with fault indication |

## Enquiring the fault memory in the control unit using the timer module

The electronic control unit can store up to 5 faults which can be read out and displayed on the timer module. The current fault is written to memory location F1. Preceding faults are written to memory locations F2 - F5.

### Fault memory enquiry

Press the  key - the heater is switched on - then press the  key, hold it down and press the  key within 2 seconds. The current error is now displayed, e.g. AF:64

The stored errors (max. 5 errors) can be called up using the  and  keys.

Fault codes, fault descriptions, remarks/remedial action are described on pages 8 to 10.



## Locking the control unit

### Overheating

In case of excess temperature at the heat exchanger (error 013, shown in display F 15), the control unit is locked.

### Canceling the control unit interlock, erasing the fault memory.



**Condition: The electrical connection from terminal 15 (ignition) to the timer module (12-pin connector, terminal jack 10) is in place.**

Press key  - the current fault (F15 or F50) is displayed - then press the  key, hold it down and press the  key within 2 seconds.

The timer module is now in the „Enquire fault memory“ program.

Now proceed as follows:

Turn off the ignition (terminal 15).

Press keys  and  simultaneously, switch on the ignition (terminal 15) and wait until the following reading appears on the display.

Reading on display after switching ignition „ON“ flashing

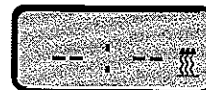

Display flashing, heating symbol not

The control unit interlock is canceled after 3 seconds, then the heater starts up.

Reading on display after heater has started symbol



Display: No current fault, heating

## Please note!

If the heater is not operated in combination with the timer module, fault code enquiry can be performed using the diagnostic unit.

Instructions are delivered with the diagnostic unit.

## Checking the operating unit using the tester

Cat. No. Tester 22 1509 89 00 00

### Steps to be taken prior to test

Apply the correct operating voltage (12 V or 24 V) to the tester. Connect the plus terminal to the red terminal jack and the minus terminal to the blue terminal jack. Ensure that the correct operating voltage is applied, otherwise the connected components could become damaged irreparably.

### Checking the operating unit

Cat. No. 12 V operating unit 25 1895 71 00 00

Cat. No. 24 V operating unit 25 1896 71 00 00

- Disconnect the plug from the operating unit.
- Connect the cable harness from the tester to the operating unit.
- Set the rotary knob of the operating unit to "Heating" the appropriate red LEDs on the tester must come on.
- Set the operating unit to „0“, then press the „LED - red“ push-button; the red pilot lamp on the operating unit must come on.
- Set the operating unit to „Heating+“, then press the „LED - green“ push-button; the appropriate red pilot lamp on the tester and the green pilot lamp on the operating unit must come on.

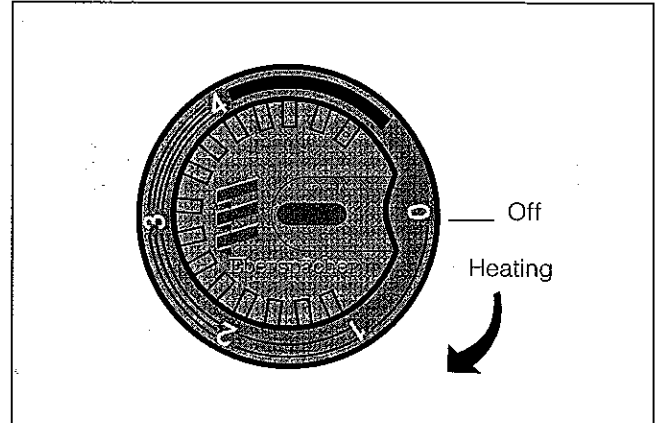

### Checking the setpoint potentiometer of the operating unit

Set the „Temp. sensor/Potentiometer“ switch on the tester to the „Potentiometer“ position and slowly turn the rotary knob on the operating unit as far as it will go. The green LED Temp. sensor/Potentiometer must remain lit without interruption.

In the event of a fault, replace the operating unit.

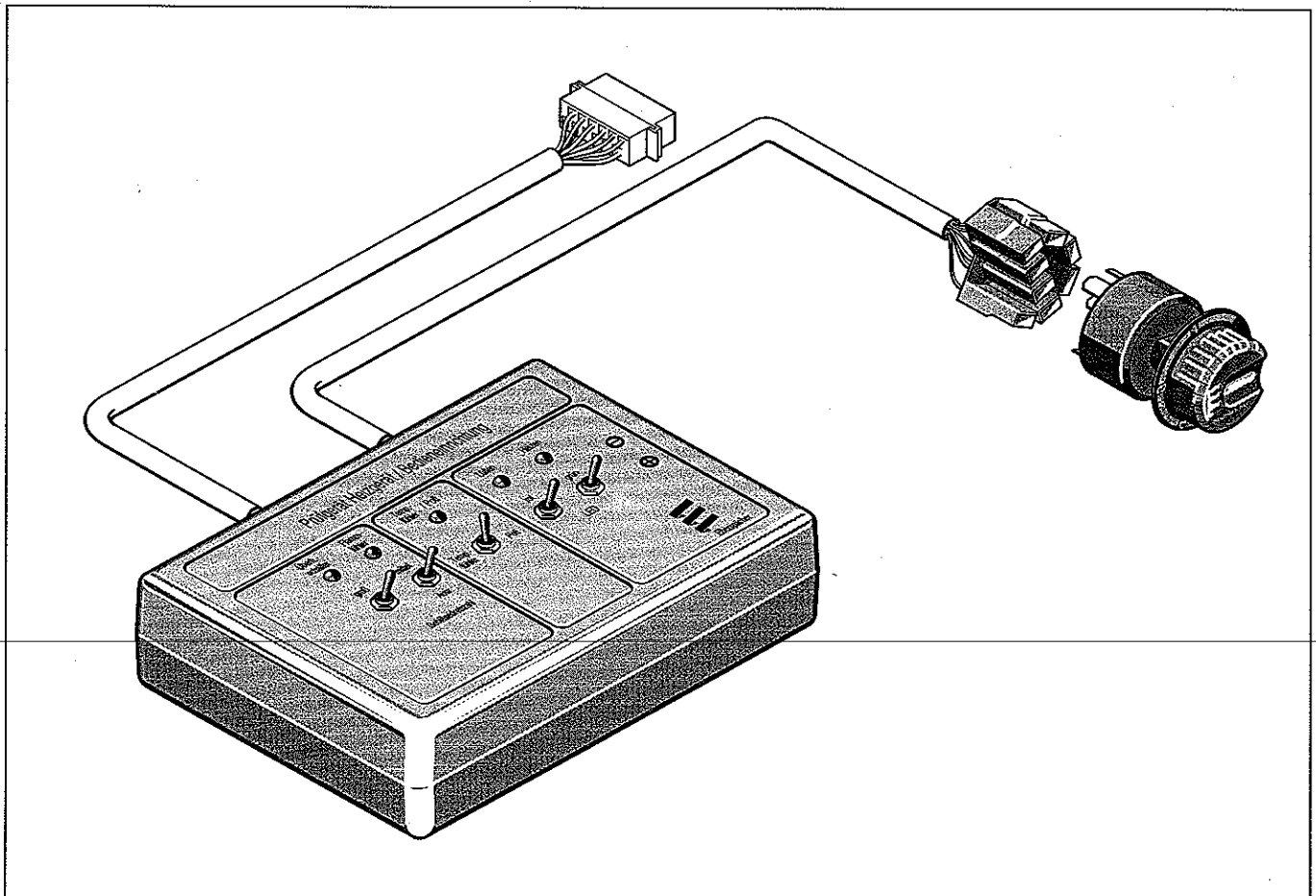

Fault Code	Fault Description	Remarks/Remedial Action
000	No fault	-----
004	Warning Short-circuit at fresh air signal output	Check the connection between the control unit, terminal jack 1, and the fresh air blower relay for short-circuit to ground. If O.K. —> replace control unit.
005	Warning Short-circuit at anti-theft alarm output	Check the connection between the control unit, terminal jack 2, and the electrical isolating switch relay or antitheft alarm input for short-circuit to ground. If O.K. —> replace control unit.
009	TRS cutout	Signal changes from (+) to (-) at the control unit connection, terminal jack 10 (D+), or plus signal is applied to the control unit connection, terminal jack 12 (HA+)
010	Overvoltage cutout	Voltage between terminal jacks 5 and 11 on control unit > 15.9 (15.2) V or 31.8 (30.4) V respectively.
011	Undervoltage cutout	Voltage between terminal jacks 5 and 11 on control unit < 10.5 (9.5) V or 21 (19) V respectively. The values in brackets apply when the glow plug is switched on.
012	Overheat	Check the connection between the control unit and the safety thermal cutout switch/overheat sensor for continuity. See diagram on page 5 for values of safety thermal cutout switch (switching value: 160° C - 190° C) or overheat sensor values. Check heating air piping for clogging and clear any blockages.
013	Excess temperature at flame sensor	Flame sensor signals temperature of > 340° C at heat exchanger. Impedance at flame sensor > 2270 Ω. See diagram on page 5 for flame sensor values.
015	Too many overheats	The control unit is interlocked after 3 successive overheats (fault codes 012, 013) Cause of overheat: Heating air piping clogged; remove any blockages Cancel the control unit interlock by erasing the fault memory using the timer module, diagnostics unit or PC.
020	Glow plug interruption	Check glow plug, replace if necessary. Nominal value: approx. 0.6 or 2 Ω Check terminal jacks 6 and 9 from control unit to glow plug for continuity. If O.K. —> replace control unit.
021	Short-circuit at glow plug output	Check control unit, terminal jack 6, up to plug connection for short-circuit. Check the glow plug for short-circuiting of the coil, replace if necessary. If O.K. —> replace control unit.





Fault Code	Fault Description	Remarks/Remedial Action
025	Short-circuit in diagnostic unit output	Check the connection from the control unit, terminal jack 4, and the diagnostic unit attachment plug for short-circuit to plus.
033	Burner motor or speed controller defective, speed deviation	Speed deviation from nominal value of $> \pm 10\%$ for longer than 30 seconds. <ul style="list-style-type: none"><li>• Speed too low: Blower blocked (check blower free - wheel and remove any foreign bodies) If O.K. —&gt; replace blower Check motor lead (1BR/1BK) and control unit output for short-circuit —&gt; replace blower</li><li>• Speed too high: Magnet in blower wheel defective or missing —&gt; replace blower Speed sensor in control unit defective —&gt; replace control unit.</li></ul>
047	Short-circuit in metering pump	Check the connection between the control unit, terminal jack 3, and the metering pump for short-circuit —> Check the metering pump, replace if necessary.
048	Metering pump interruption	Check the connection between the control unit, terminal jack 3, and the metering pump for continuity —> Check the metering pump for continuity, replace if necessary. Check the minus supply of the metering pump (1 BR) up to the grounding point.
050	Too many failed starts	The control unit was interlocked after having been switched on 10 times in succession (=20 failed starts without flame detection - fault code 052). Check the fuel supply, glow plug, exhaust piping and combustion air piping. Cancel the interlock by clearing the error memory with the timer module, diagnostic unit or PC.
051	Flame message is displayed when heater is switched on	Impedance at flame sensor $> 57^\circ \text{C}$ (1220 $\Omega$ ) after 15 minutes of cooling with cold air. See diagram on page 5 for flame sensor values.
052	Safety time exceeded - heater does not start	No flame was detected during the start-up phase. Flame sensor value $< 100^\circ \text{C}$ (1380 $\Omega$ ). Check the flame sensor, replace if necessary. Check the fuel supply and glow plug. See diagram on page 5 for flame sensor values. Check the exhaust piping and combustion air piping.
053	Flame loss in „Power“ setting / start-up	Heater was ignited (flame detected) and indicates flame loss in a specific setting or the flame is lost during the start-up phase. Check the fuel flow rate and fuel supply. Check the exhaust piping and combustion air piping. If combustion is OK, —> check flame sensor, replace if necessary. See diagram on page 5 for flame sensor values.
054	Flame loss in „High“ setting	
055	Flame loss in „Medium“ setting	
056	Flame loss in „Low“ setting	

<b>Fault code</b>	<b>Fault Description</b>	<b>Remarks/Remedial Action</b>
060 061	External temperature control sensor interruption Short-circuit in external temperature control sensor	Temperature control sensor signals temperature value outside control range. Check connecting leads 0.5 GR and 0.5 BR/WH. Impedance between terminals 8 and 13 > 2800 Ω (in the event of interruption) Impedance between terminals 8 and 13 < 280 Ω (in the event of short-circuit) See diagram on page 5 for temperature sensor values.
062 063	Setpoint potentiometer interruption Short-circuit in setpoint potentiometer	Potentiometer of operating unit signals setpoint outside control range. Check the connecting leads. Impedance between terminals 7 and 13 > 2800 Ω (in the event of interruption) Impedance between terminals 7 and 13 < 280 Ω (in the event of short-circuit) Normal values: 1740 Ω - 2180 Ω (±80 Ω)
064 065	Flame sensor interruption Short-circuit in flame sensor	Flame sensor signals temperature value outside measurement range. Check the connecting leads. Impedance > 3200 Ω (in the event of interruption) Impedance < 200 Ω (in the event of short-circuit) See diagram on page 5 for flame sensor values.
071 072	Overheat sensor interruption Overheat sensor short-circuit	Overheat sensor signals temperature value outside measurement range. Check the connecting leads. Impedance > 3200 Ω (in the event of interruption) Impedance < 200 Ω (in the event of short-circuit) See diagram on page 5 for flame sensor values.
090 091	Watchdog reset (internal fault / reset) External interference (external fault / reset)	Internal error in microprocessor/memory → replace control unit. Fault in control unit caused by interference voltages radiating from vehicle electrical system. Possible causes:
092 093 094	Control unit defective (ROM error) Control unit defective (RAM error) Control unit defective (EEPROM error)	Poor-quality battery, charger → Eliminate interference voltages. Internal error in microprocessor/memory detected → replace control unit.
096	Control unit defective Internal temperature sensor defective	Replace the control unit or use an external temperature sensor.
097	Control unit defective Oscillator or undervoltage fault	Replace control unit.
099	Control unit defective Internal glow plug transistor defect	Replace control unit.



**Circuit diagram of heater** (Control elements see page15)

**Version:**

Glow plug (-)pulsed

- 20 1748 01
- 25 1895 01
- 25 1896 01
- 25 1924 01

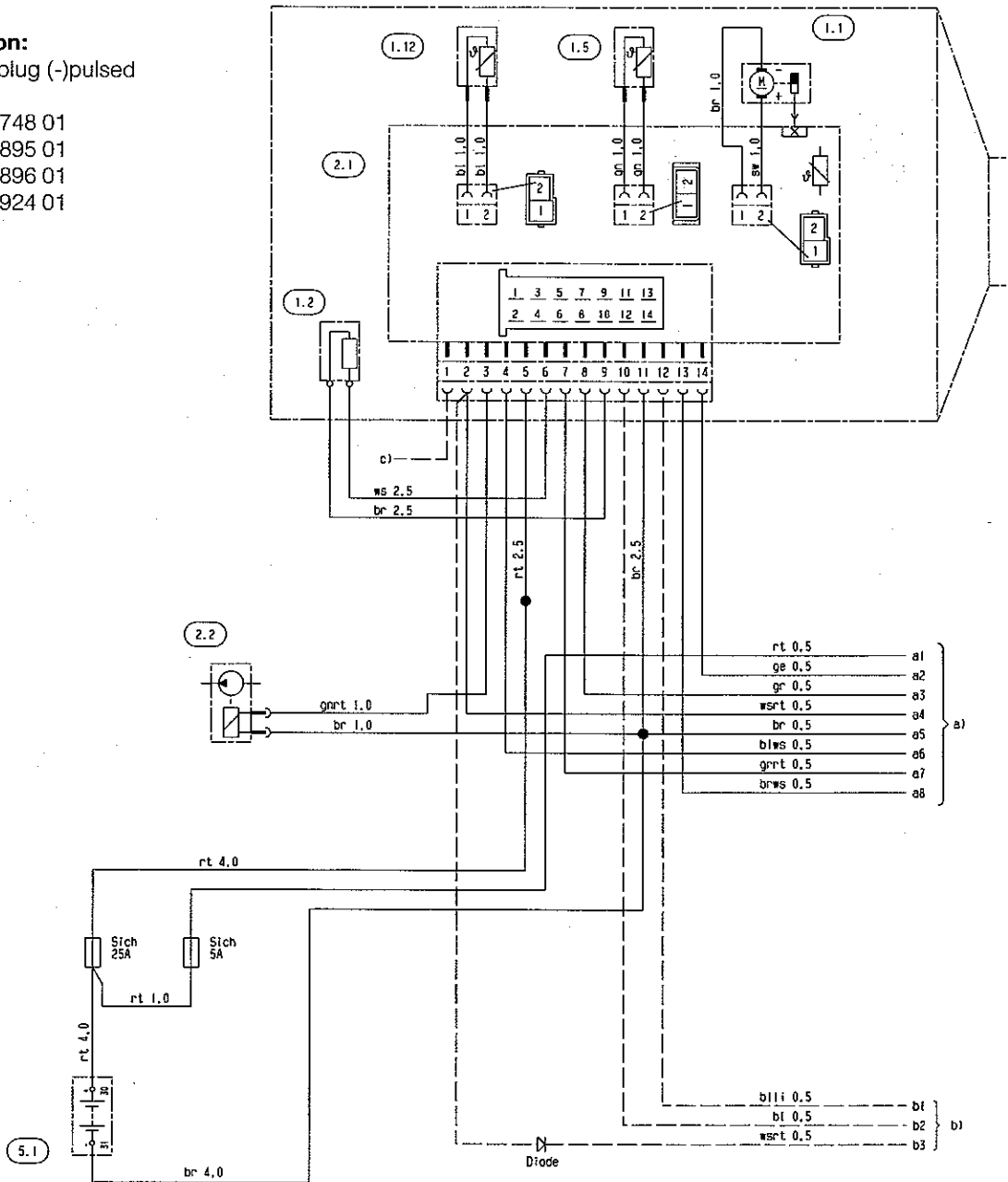

**Parts list**

- |      |                              |    |   |
|------|------------------------------|----|---|
| 1.1  | Burner motor                 | b) | With cable harness 22 1000 30 61 00 only  |
| 1.2  | Glow plug                    | b1 | HA+ auxiliary drive, for TRS heaters only |
| 1.5  | Safety thermal cutout switch | b2 | D+ alternator, for TRS heaters only       |
| 1.12 | Flame sensor                 | b3 | + Depress battery disconnecting switch    |
| 2.1  | Electronic control unit      |    | Switch off anti-theft alarm               |
| 2.2  | Metering pump                | c) | Optional                                  |
| 5.1  | Battery                      |    | Fresh air blower, vehicle blower control  |

1895 6 01 C

- a) Connection for control elements and external sensor according to circuit diagram 25 1895 00 97 01
- a1 Supply to plus terminal 40
- a2 Switch-on signal S+
- a3 Temperature, actual value
- a4 + Depress battery disconnecting switch  
Switch off anti-theft alarm
- a5 Supply to minus terminal 31
- a6 Diagnosis
- a7 Temperature setpoint
- a8 Sensor, reference signal

**Cable colours**

- |    |        |
|----|--------|
| sw | Black  |
| ws | White  |
| rt | Red    |
| ge | Yellow |
| gn | Green  |
| vi | Violet |
| br | Brown  |
| gr | Grey   |
| bl | Blue   |
| li | Lilac  |

**Circuit diagram of heater** (Control elements see page 15)

**Version:**

Glow plug (+) pulsed with current regulator

- 20 1761 01
- 25 1965 01
- 25 1966 01
- 25 1957 01
- 25 1971 01

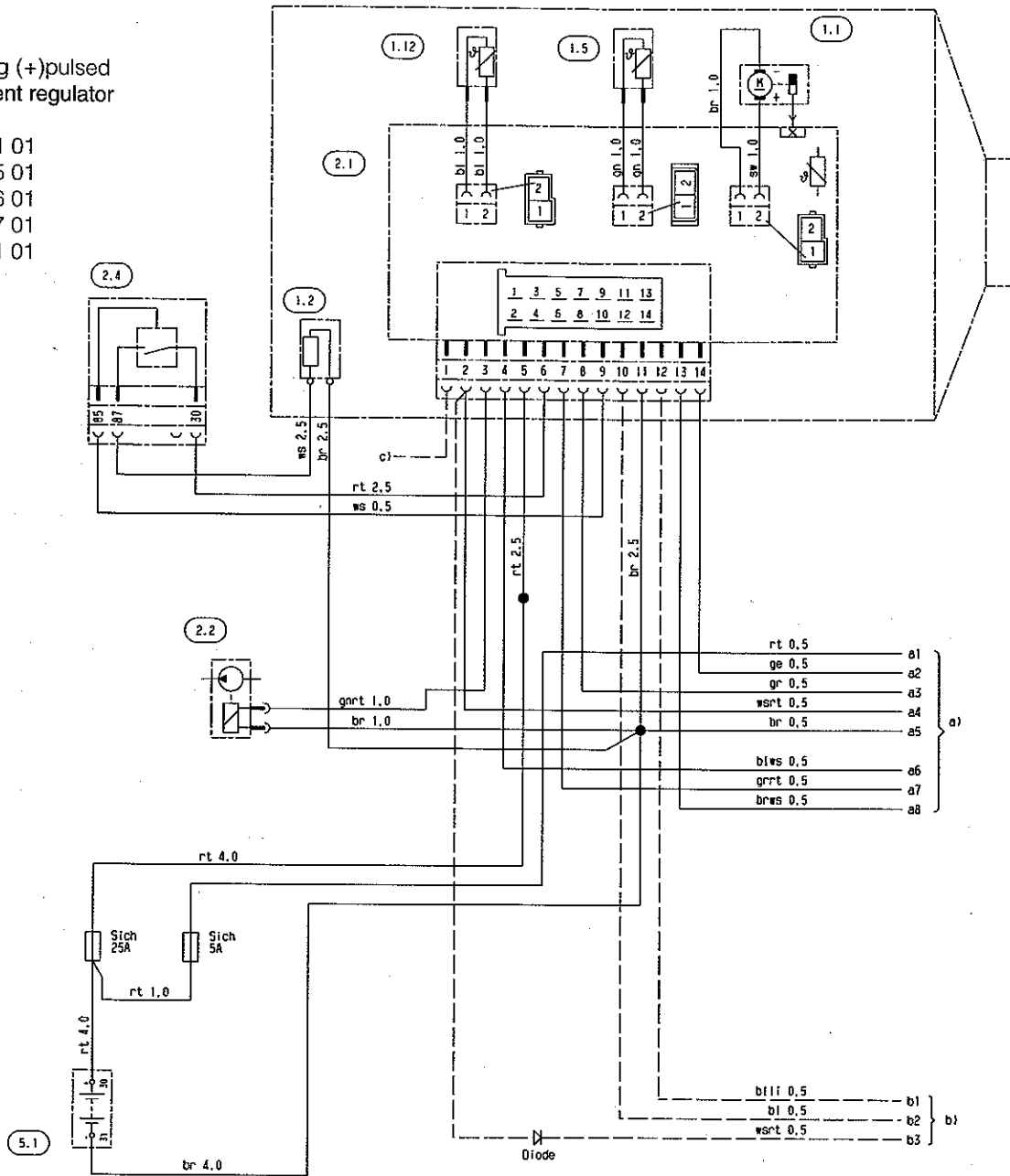

**Parts list**

- 1.1 Burner motor
- 1.2 Glow plug
- 1.5 Overheat sensor
- 1.12 Flame sensor
- 2.1 Electronic control unit
- 2.2 Metering pump
- 5.1 Battery

- a8 Sensor, reference signal
- b) With cable harness 22 1000 30 60 00 only
- b1 HA+ auxiliary drive, for TRS heaters only
- b2 D+ alternator, for TRS heaters only
- b3 + Depress battery disconnecting switch  
Switch off anti-theft alarm
- e) Optional  
Fresh air blower, vehicle blower control

- a) Connection for control elements and external sensor according to circuit diagram 25 1895-00 97 01
- a1 Supply to plus terminal 40
- a2 Switch-on signal S+
- a3 Temperature, actual value
- a4 + Depress battery disconnecting switch  
Switch off anti-theft alarm
- a5 Supply to minus terminal 31
- a6 Diagnosis
- a7 Temperature setpoint

**Cable colours**

sw	Black	vi	Violet
ws	White	br	Brown
rt	Red	gr	Grey
ge	Yellow	bl	Blue
gn	Green	li	Lilac

1965 6 01 B



### Circuit diagram of heater - Standard (Control elements see page 15)

#### Version:

Glow plug (+) pulsed

- 20 1766 01
- 25 1976 01
- 25 1977 01
- 25 1979 01
- 25 1978 01

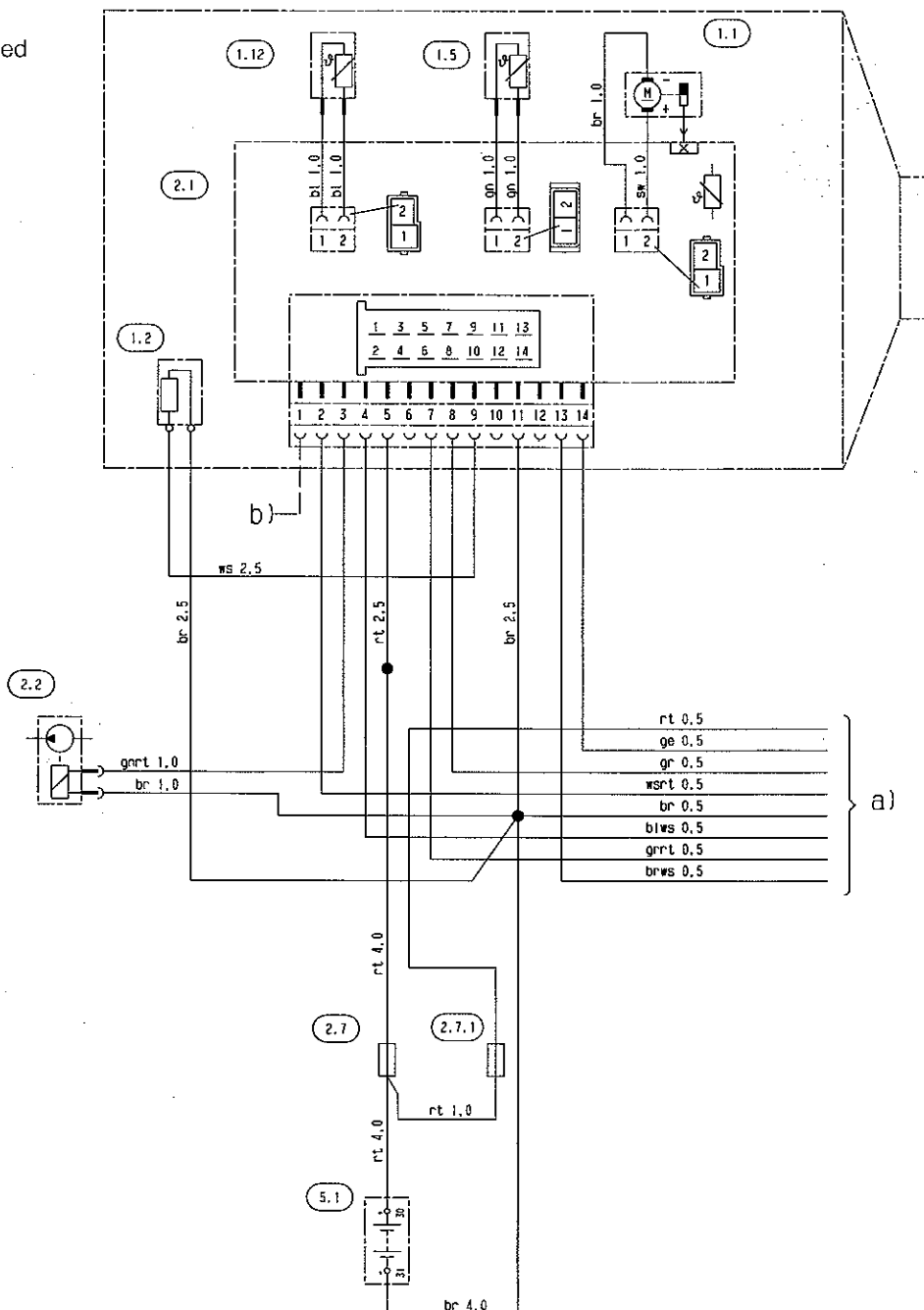

1976 6 01 B

#### Parts list

- |       |                               |
|-------|-------------------------------|
| 1.1   | Burner motor                  |
| 1.2   | Glow plug                     |
| 1.5   | Overheat sensor               |
| 1.12  | Flame sensor                  |
| 2.1   | Electronic control unit       |
| 2.2   | Metering pump                 |
| 2.7   | Fuse 12 V = 25 A, 24 V = 15 A |
| 2.7.1 | Fuse 15 A                     |
| 5.1   | Battery                       |

- |    |   |
|----|---|
| a) | Connection for control elements and external sensor according to circuit diagram 25 1895 00 97 01 |
| a1 | Supply to plus terminal 40  |
| a2 | Switch-on signal S+   |
| a3 | Temperature, actual value   |
| a4 | + Depress battery disconnecting switch<br>Switch off anti-theft alarm                             |
| a5 | Supply to minus terminal 31   |

- |    |   |
|----|---|
| a6 | Diagnosis   |
| a7 | Temperature setpoint  |
| a8 | Sensor, reference signal  |
| b) | With cable harness 22 1000 30 93 00 only                              |
| b1 | HA+ auxiliary drive, for TRS heaters only                             |
| b2 | D+ alternator, for TRS heaters only                                   |
| b3 | + Depress battery disconnecting switch<br>Switch off anti-theft alarm |
| c) | Optional<br>Fresh air blower, vehicle blower control                  |

#### Cable colours

- |    |        |
|----|--------|
| sw | Black  |
| ws | White  |
| rt | Red    |
| ge | Yellow |
| gn | Green  |
| vi | Violet |
| br | Brown  |
| gr | Grey   |
| bl | Blue   |
| li | Lilac  |

**Circuit diagram of heater - TRS** (Control elements see page15)

**Version:**

Glow plug (+)pulsed

- 20 1766 01
- 25 1976 01
- 25 1977 01
- 25 1979 01
- 25 1978 01

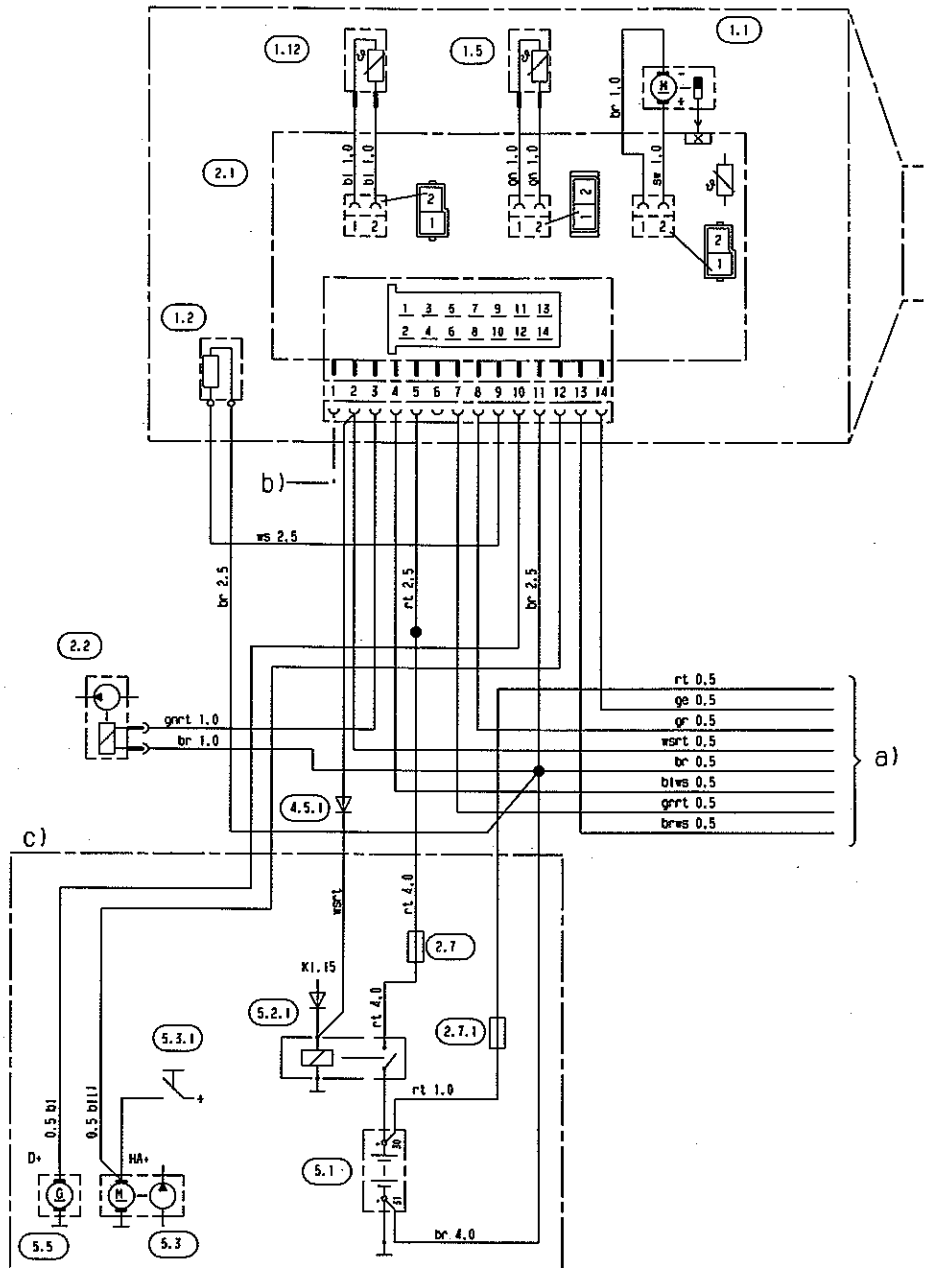

1976 6 02 A

**Parts list**

- 1.1 Burner motor
- 1.2 Glow plug
- 1.5 Overheat sensor
- 1.12 Flame sensor
- 2.1 Electronic control unit
- 2.2 Metering pump
- 2.7 Fuse 12 V = 25 A, 24 V = 15 A
- 2.7.1 Fuse = 5 A
- 4.5.1 Diode TRS
- 5.1 Battery
- 5.2.1 Battery disconnecting
- 5.3 Auxiliary drive HA +
- 5.3.1 Switch auxiliary drive
- 5.5 Generator D +

- a) Connection for control elements and external sensor according to circuit diagram
- rt Supply to plus terminal 40
- ge Switch-on signal S+
- gr Temperature, actual value
- wsrt + Depress battery disconnecting switch
- br Switch off anti-theft alarm
- br Supply to minus terminal 31
- blws Diagnosis
- grrt Temperature setpoint
- brws Sensor, reference signal
- b) Optional  
Fresh air blower, vehicle blower control
- c) TRS:  
transport of dangerous goods  
by commercial vehicles  
(e.g. tankers)

**Cable colours**

- sw Black
- ws White
- rt Red
- ge Yellow
- gn Green
- vi Violet
- br Brown
- gr Grey
- bl Blue
- li Lilac



## Circuit diagram of control elements

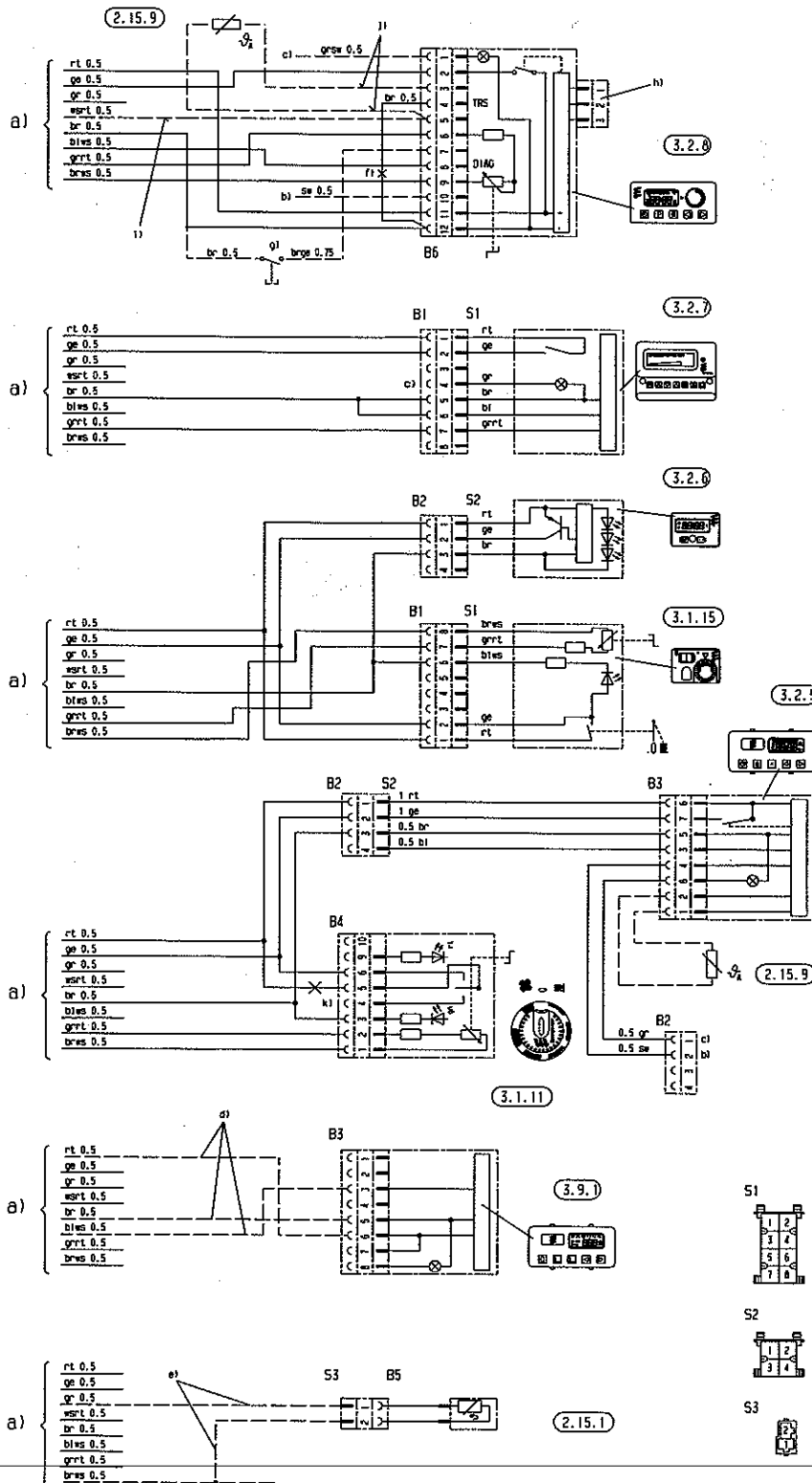

## Parts list

- 2.15.1 Sensor for room temperature
  - 2.15.9 Sensor, external temperature
  - 3.2.5 Timer, rectangular
  - 3.2.6 Timer, mini
  - 3.2.7 Timer, rectangular
  - 3.2.8 Timer, rectangular
  - TRS heater potentiometer
  - 3.1.11 Operating unit, round
  - 3.1.15 Operating unit, mini (without sensor)
- b) Terminal 15  
 c) Lighting, terminal 58  
 e) Connection, external temperature sensor  
 f) Cable jumper is not required with TRS heater (0.5 BR)  
 g) Connection for external momentary-contact push-button for heater  
 h) Connection for radio control module  
 i) Connection for feedback from control unit, available with TRS heater only  
 j) Connection for outside temperature sensor, not available with TRS heater  
 k) For timer connection  
 Cut cable here
- a) Connection for operating elements and external sensor  
 a1 Supply to plus terminal 40  
 a2 Switch-on signal S+  
 a3 Temperature, actual value  
 a4 + Depress battery disconnecting switch  
 a5 Switch off anti-theft alarm  
 a6 Supply to minus terminal 31  
 a6 Diagnosis  
 a7 Temperature setpoint  
 a8 Sensor, reference signal

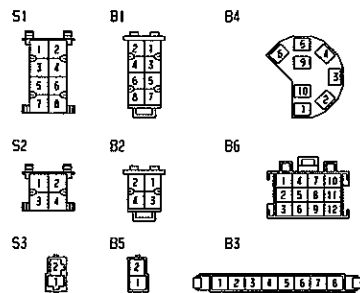

1895 7 01 C

## Cable colours

sw	Black	vi	Violet
ws	White	br	Brown
rt	Red	gr	Grey
ge	Yellow	bl	Blue
gn	Green	li	Lilac

## Repair instructions

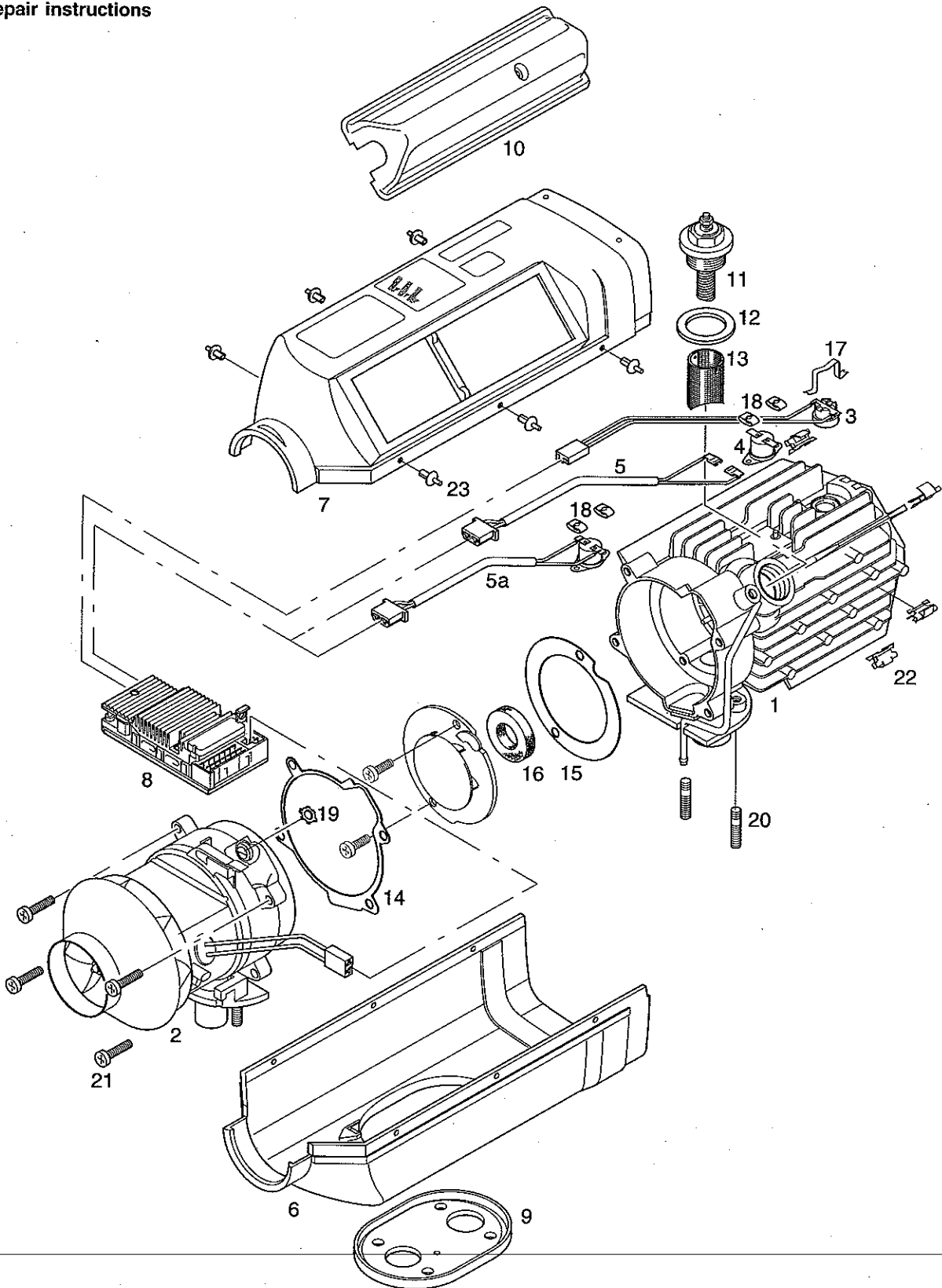

1	Heat exchanger	8	Electronic control unit	16	Ring seal
2	Blower	9	Flange seal	17	Clip
3	Flame sensor	10	Cap	18	Safety clamps
4	Safety thermal cutout switch	11	Glow plug	19	Toothed ring
5	Cable harness, safety thermal cutout switch	12	Ring seal	20	Stud bolt
5a	Overheat sensor	13	Lining, glow plug connection piece	21	Fillister head screw
6	Lower casing half	14	Seal	22	U-clip
7	Upper casing half	15	Sealing disk	23	Body-bound rivet





## Repair steps

- 1 Remove/install glow plug
- 2 Remove/install plug screen
- 3 Remove/install electronic control unit
- 4 Remove cap  
Remove reduction hood  
Detach casing
- 5 Remove/install safety thermal cutout switch or  
overheat sensor
- 6 Remove/install flame sensor
- 7 Remove combustion air blower from heat  
exchanger
- 8 Clean heat exchanger

### 1 Remove/install glow plug

#### Attention!

The glow plug connector is live, therefore disconnect the 14-pin plug from the control unit.

Slacken the hexagon socket and remove the cap. Unplug the glow plug connector and unscrew the glow plug.

**Important!** Always use a new seal when replacing the glow plug.  
Cat. No. of seal 25 1830 01 01 01

### 2 Remove/install plug screen

Remove plug screen from plug connection using pliers. Clean off the plug vent using compressed air.

When putting the plug screen back in, ensure correct positioning of the lug and parting joint - see sketch 1 or 2. Carefully slide in the plug screen as far as it will go. The hole for the plug vent (2 mm dia.) must then be free (D 1 L C compact).

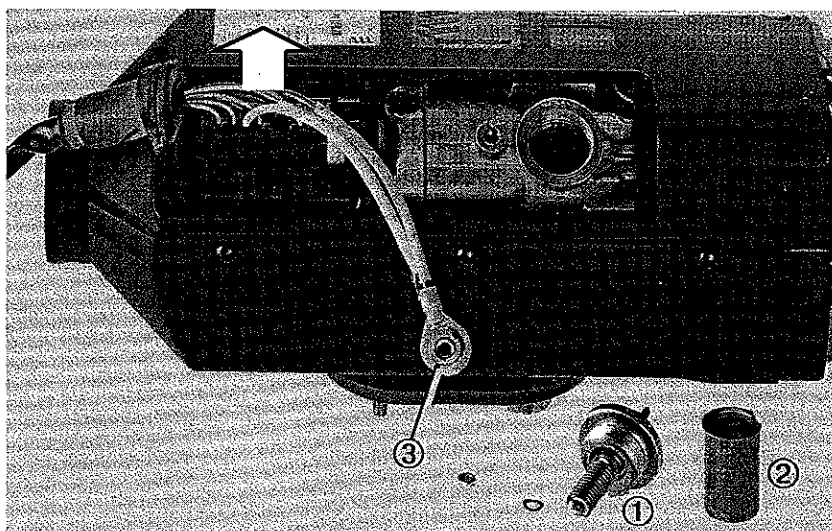
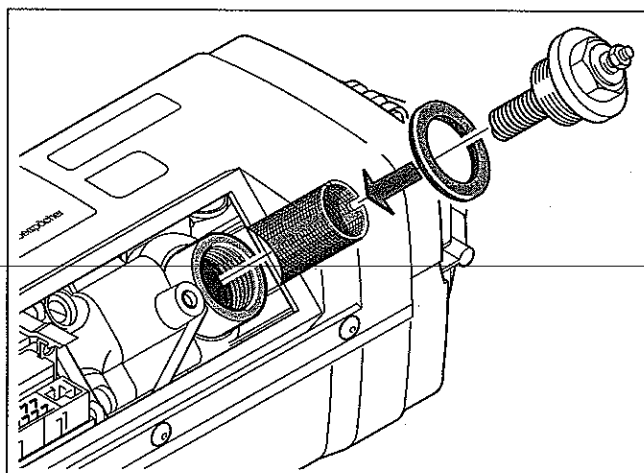

Figure 1

- 1 Glow plug
- 2 Plug screen
- 3 Glow plug connector

### Installation position of plug screen in B 1 L C compact



Sketch 1

### Installation position of plug screen in D 1 L C compact

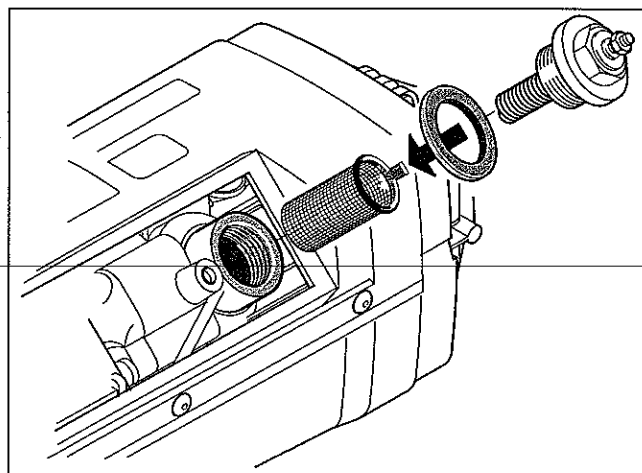

Sketch 2

### 3 Remove/install electronic control unit

Unplug the two connectors from the control unit. Cancel the control unit interlock and remove the control unit from the guide. Then unplug both connectors from the rear of the control unit.

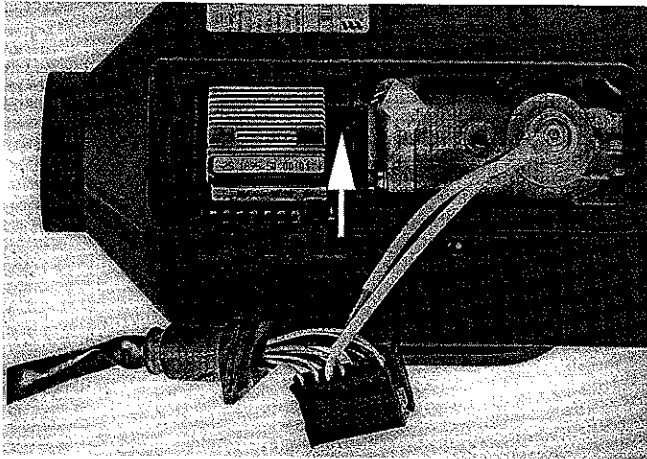

Figure 2

### 4 Remove cap, remove reduction hood detach casing

Slacken the hexagon socket head cap screw and detach the cap. Detach the reduction hood using a screwdriver. Remove the body-bound rivets and then detach the casing halves. Use new rivets for reassembly.

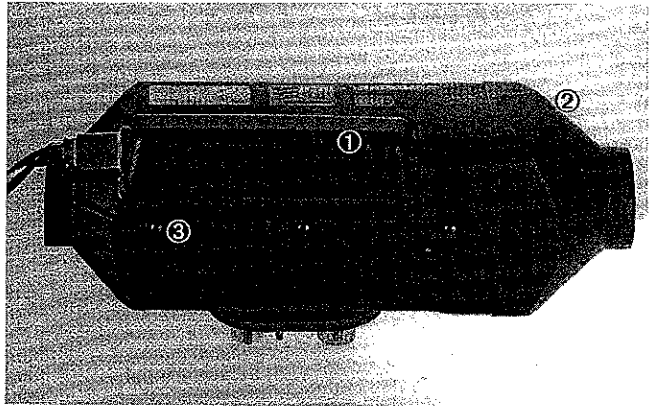
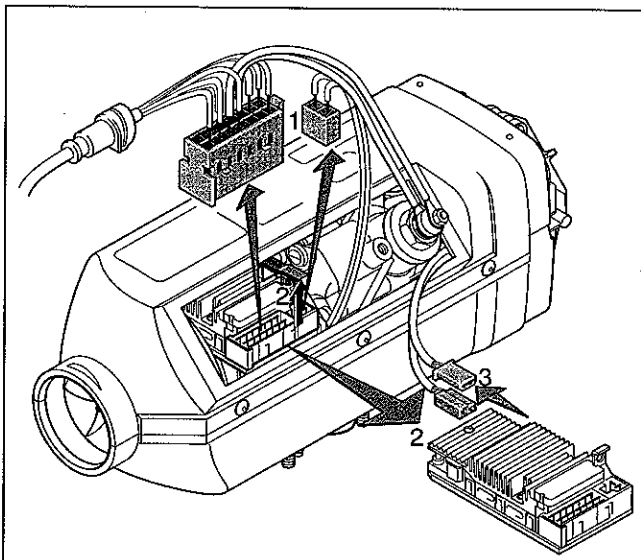
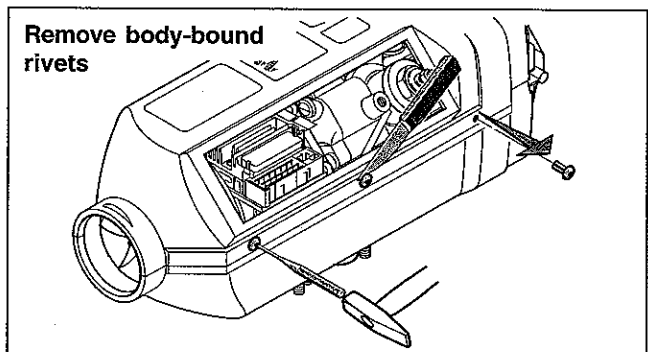

Figure 3

- 1 Cap with hexagon socket
- 2 Reduction hood
- 3 Body-bound rivet



Sketch 3



Sketch 4

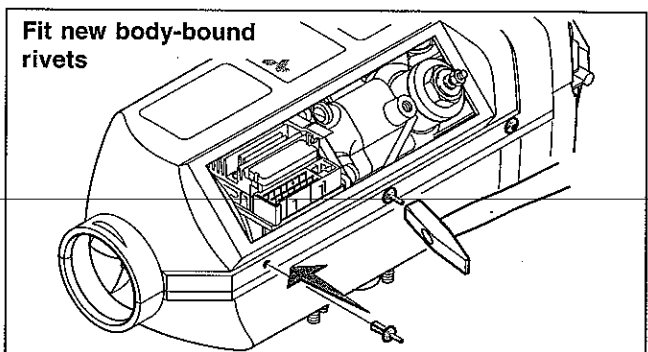

Sketch 5



### 5 Remove/install safety thermal cutout switch or overheat sensor

Remove the two receptacles from the safety thermal cutout switch.  
Detach the safety clamps from the safety thermal cutout switch or overheat sensor.  
Use new safety clamps for reassembly.

### 6 Remove/install flame sensor

Unplug the connector from the control unit.  
Remove the retaining spring from the flame sensor.

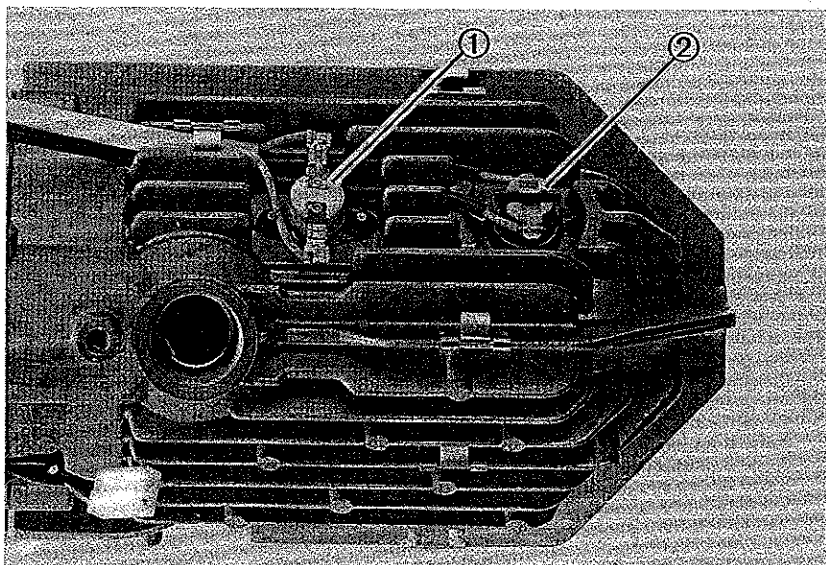
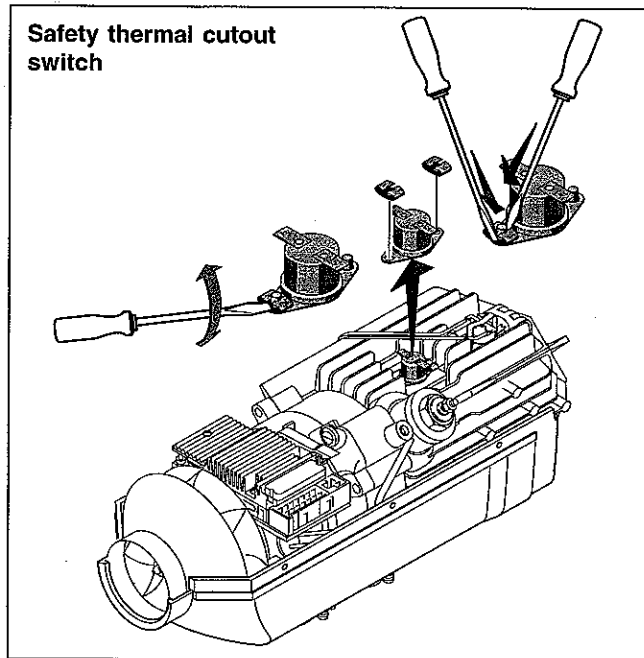
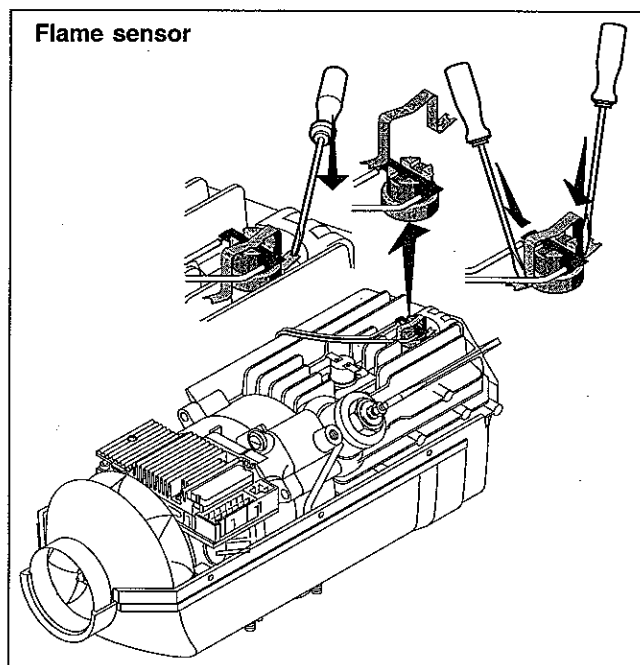

Figure 4

- 1 Safety thermal cutout switch
- 2 Flame sensor



Sketch 6



Sketch 7

#### Please note!

If the safety thermal cutout switch is defective, a new **overheat sensor** and a **new control unit** must be installed.

Overheat sensor repair kit	Cat. No.
B 1 L C compact - 12 V	20 1748 99 15 00
D 1 L C compact - 12 V	25 1895 99 15 00
D 1 L C compact - 24 V	25 1896 99 15 00

The following components are included in the repair kit:

- 1 Overheat sensor
- 1 Control unit
- 7 Body-bound rivets
- 2 Safety clamps (Duo-Clip)

## 7 Remove combustion air blower from heat exchanger

Unplug the connector from the „Flame sensor“ cable harness and the connector from the „Overheat sensor“ on the control unit.

Remove the Phillips-head screws from the blower. Detach the combustion air blower and the seal from the heat exchanger.

### Renew the seal.

The following work must be performed beforehand:

- Remove the cap
- Detach the cable harness
- Remove the reduction hood
- Remove the casing halves

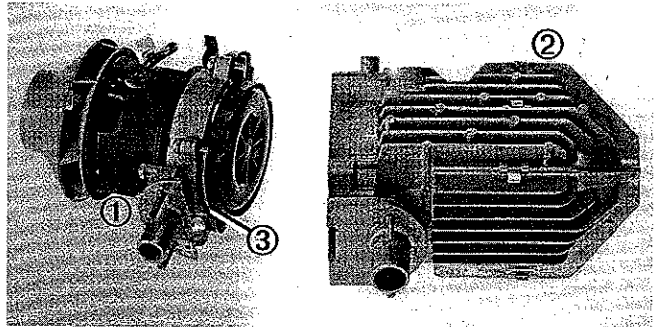

Figure 5

- 1 Blower
- 2 Heat exchanger
- 3 Seal

## 8 Clean heat exchanger

Unscrew the cover from the heat exchanger. Remove the sealing disk and ring seal. Renew the sealing disk. Check the ring seal, replace if necessary.

- 1 Cover
- 2 Seal
- 3 Ring seal

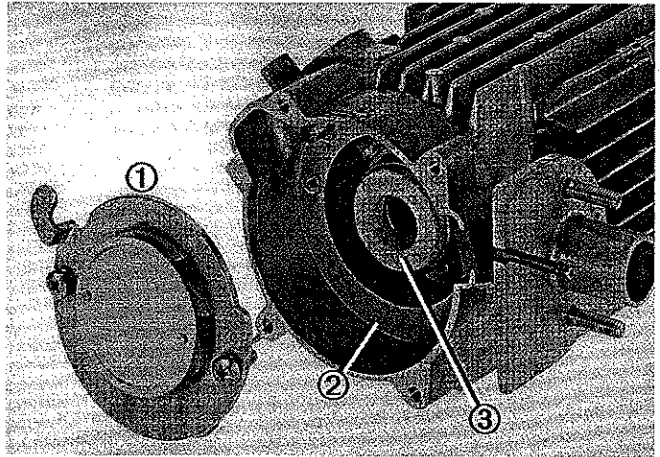
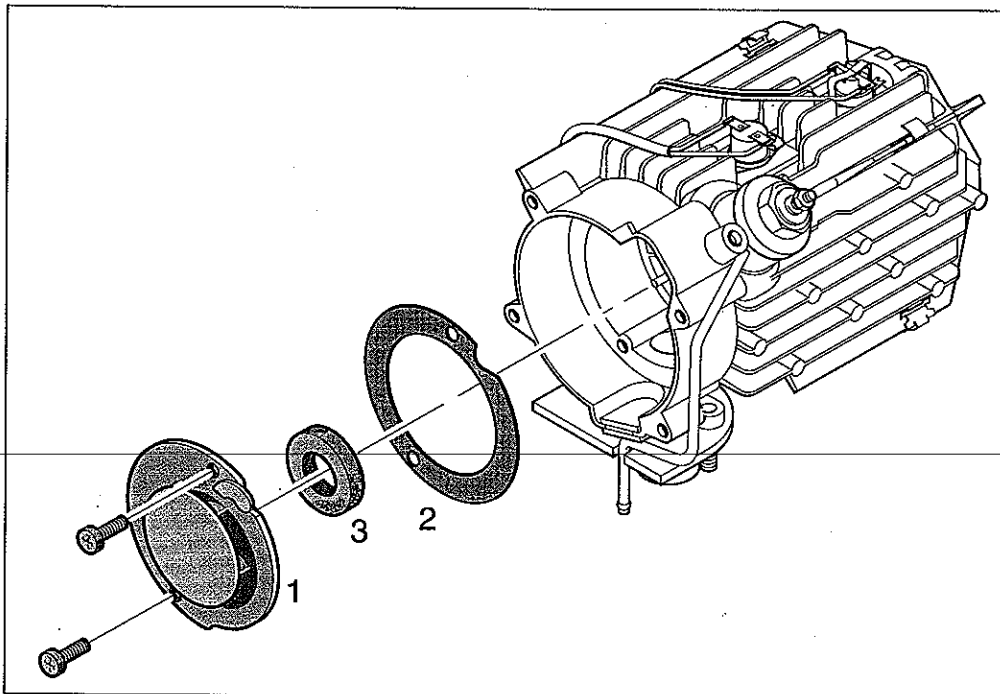

Figure 6



Sketch 8



## Fuel quantity measurement

### Preparation for measurement

Detach the fuel line from the heater and place it in a measuring glass (10 cc. capacity).

Switch on the heater.

After about 25 seconds, the metering pump starts to pump fuel.

When the fuel is coming out smoothly and free of bubbles, the fuel line is filled and bled.

Switch off the heater and empty the measuring glass.

### Measurement

Switch on the heater.

After about 25 seconds, the metering pump starts to pump fuel.

Keep the measuring glass at the level of the plug during measurement.

After about 90 seconds, fuel pumping is switched off automatically.

**Switch off the heater, otherwise start-up is repeated. Measure the fuel quantity in the measuring glass.**

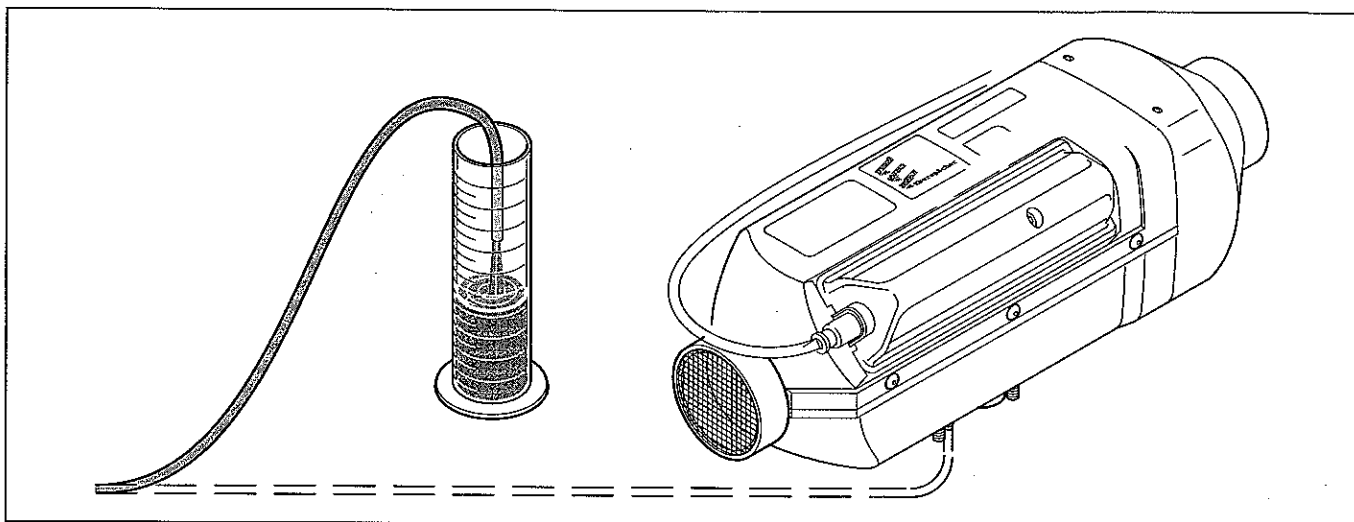

Sketch 9

### Evaluation

Plot the reading onto the diagram.

Fuel consumption is OK when the value lies within the shaded area.

If the value lies outside the shaded area, the fuel metering pump must be replaced.

Heaterversion	B 1 LC compact	D 1 LC compact
<b>Fuel consumption</b> [cm <sup>3</sup> / 90 s]		
- Set value	6,1	4,0
- Max. value	7,0	4,7
- Min. value	5,2	3,4